

# EDCON-COMPONENTS

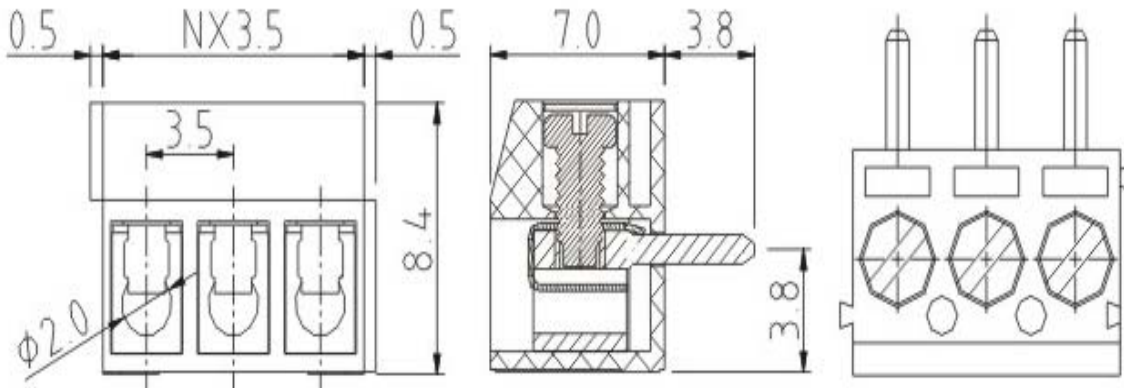

## Drawing



## P.C.B. Layout

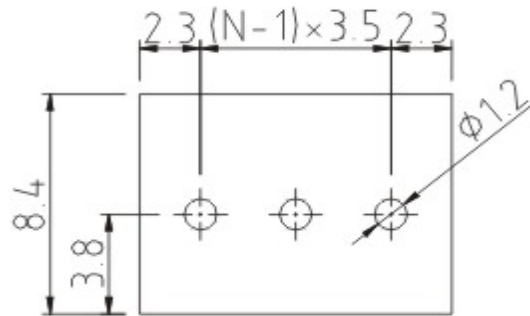

## Specification

### APPROVAL



#### Electrical:

Standard	UL
Rated voltage	125V
Rated current	10A
Wire range	26-16AWG
Withstanding voltage	1,25KV

#### Mechanical

Ambient temperature	-40°C ~ +115°C
Soldering temperature	250°C ±10°C/5sec
Strip length	5~6mm
Screw, Torque	M2, 0.2Nm (1.7Lb-In.)

#### Dimensions

Pitch	3.50mm
Poles	2P + 3P

#### Material

Housing	Thermoplastic (UL94V-0)
Surface of solder tail	Tin plated
Wire guard	Stainless steel
Terminal screw	Steel Zinc plated
Metal housing	Brass(CuZn)



Wire Protector Terminal Block /  
Pitch 3.50mm

Part No.: A12G006

Customer:

DRW:	Bill	CHKD	Lord	MATL:	Jimmy	TOLERANCE	Sam	DATE	14.3.2009
APPD:	Louis			FINISH	Georg			Sheet No.	1 from 2

[www.edcon-components.com](http://www.edcon-components.com)

email: [info@edcon-components.com](mailto:info@edcon-components.com)

# EDCON-COMPONENTS



## Ordering Informations

Serie	-	No. of Pole	Body-Color	-	wire protector	-	Customer Request
<b>A12G006</b>	-	<b>XX</b>	<b>XX</b>	-	<b>X</b>	-	<b>X</b>

XX = total	<b>WH</b> - white
	<b>GN</b> - green
	<b>GR</b> - gray (standard)
	<b>PG</b> - Phoenix Green
	<b>OR</b> - orange (standard)
	<b>BK</b> - black
	<b>BL</b> - blue
	<b>LG</b> - light gray

<b>1</b> - with wire protector
<b>2</b> - without wire protector



Wire Protector Terminal Block /  
Pitch 3.50mm

Part No.: A12G006

Customer:

DRW:	Bill	CHKD	Lord	MATL:	Jimmy	TOLERANCE	Sam	DATE	14.3.2009
APPD:	Louis			FINISH	Georg			Sheet No.	2 from 2

[www.edcon-components.com](http://www.edcon-components.com)

email: [info@edcon-components.com](mailto:info@edcon-components.com)