

Data Sheet

Screwless Terminal Block

Pitch: 15,00 mm

Serie: A11V002

Customer Information for special Item

EDCON Customer : 0

Customer Version No. : 0

EDCON-COMPONENTS



Technical Discription

Drawing (Dimension in mm)

Electrical

Standard
 Rated voltage
 Rated current
 Wire range
 Withstanding voltage

UL	IEC
600V	450V, 800V
50A	57A
24-6 AWG	10.0mm ²
AC2500V/1Min	

Mechanical

Wire strip length
 Operating temperature

12mm
 -40°C ~ +105°C

Dimensions

Pitch
 Poles

15.00mm
 1P - xxP

Material

Housing
 Pin header
 Wire guard

PA66 (UL94V-0)
 Phosphor Bronze, Tin plated
 Stainless steel

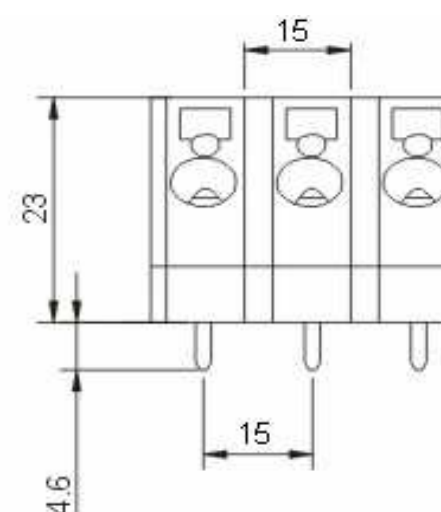
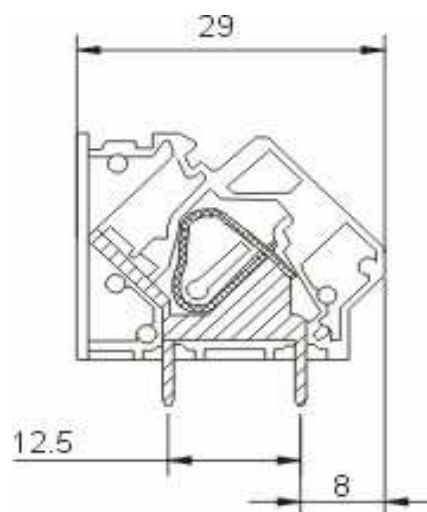

Screwless Terminal Block

Part No.: **A11V002**

Customer:

DRW:	Jason	CHKD	Wilson	MATL:	Wilson	TOLERANCE	Mason	DATE	10.02.2014
APPD:	Schumi			FINISH	Jamy		Sheet No.		1 from 4

EDCON-COMPONENTS



Ordering Informations

Serie	No. of Pos.	Body Color	Approval	Approval Code	ROHS	Packing	EDCON Cust. No.	Customer Version		
-------	-------------	------------	----------	---------------	------	---------	-----------------	------------------	--	--

A11V002	02	GN	N	N	R	B				
----------------	-----------	-----------	----------	----------	----------	----------	--	--	--	--

Pitch 15,00	02 = Number of Pos. Standard 2~12 Pos.	GY = Gray (Standard) GN = Green OR = Orange BK = Black	N = No Approval 1 = Approval for Material 2 = Approval for Terminal Block	N = NON Approval A = UL /UR Approval Please consult EDCON for available B = VDE Approval Please consult EDCON for available C = TÜV Approval Please consult EDCON for available	R = ROHS Conform N = NON ROHS Conform	B = Standard Package I = Individual Package	xxxxxx = Customer Number	xxx = Customer Version ??(Printing)		
----------------	--	---	--	--	--	--	---------------------------------	--	--	--

Screwless Terminal Block

Part No.: **A11V002**

DRW:	Jason	CHKD	Wilson	MATL:	Wilson	TOLERANCE	Mason	DATE	10.02.2014
APPD:	Schumi			FINISH	Jamy		Sheet No.		3 from 4

Customer:



Soldering Profile Curve

Classification Reflow Profile (JEDEC J-STD-020C)



Screwless Terminal Block

Part No.: **A11V002**

Customer:

DRW:	Jason	CHKD	Wilson	MATL:	Wilson	TOLERANCE	Mason	DATE	10.02.2014
APPD:	Schumi			FINISH	Jamy		Sheet No.	4 from 4	

