

# Data Sheet

## Screwless Terminal Block

**Pitch: 10,16 mm**

**Serie: A11U019**

### Customer Information for special Item

**EDCON Customer : 0**

**Customer Version No. : 0**

# EDCON-COMPONENTS



## Technical Description

## Drawing (Dimension in mm)

### Electrical

Standard  
 Rated voltage  
 Rated current  
 Wire range  
 Withstanding voltage

UL	IEC
300V	250V, 450V
10A	12A
28-12 AWG	2.5mm <sup>2</sup>
AC2000V/1Min	

### Mechanical

Wire strip length  
 Operating temperature

5 ~ 6mm  
 -40°C ~ +105°C

### Dimensions

Pitch  
 Poles

10.16mm  
 3x (1P - xxP)

### Material

Housing  
 Pin header  
 Wire guard

PA66 (UL94V-0)  
 Copper, Tin plated  
 Stainless steel

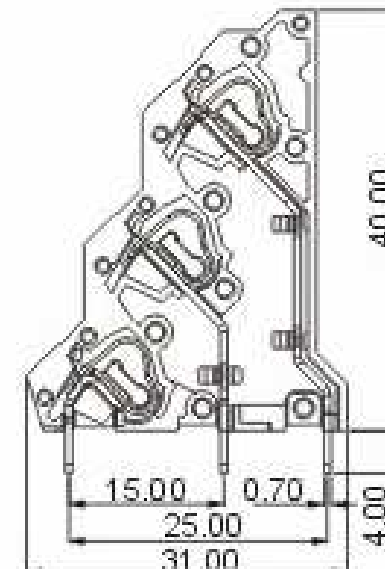
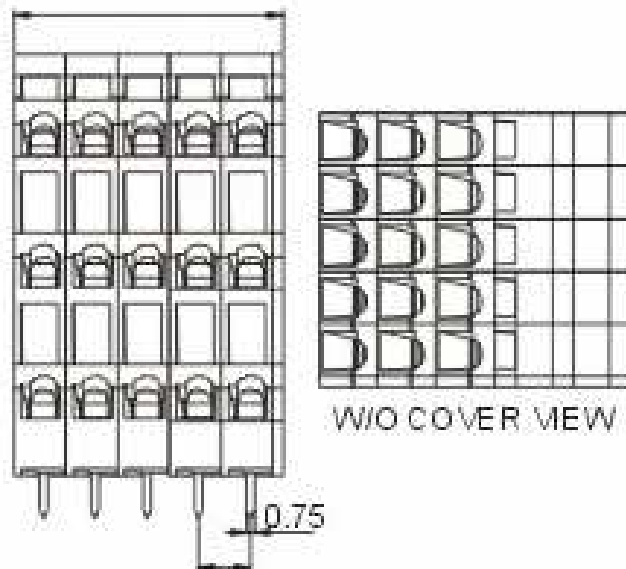

### Screwless Terminal Block

Part No.: **A11U019**

Customer:

DRW:	Jason	CHKD	Wilson	MATL:	Wilson	TOLERANCE	Mason	DATE	10.02.2014
APPD:	Schumi			FINISH	Jamy		Sheet No.	1 from 4	



# EDCON-COMPONENTS



## Ordering Informations

Serie	No. of Pos.	Body Color	Approval	Approval Code	ROHS	Packing	EDCON Cust. No.	Customer Version		
-------	-------------	------------	----------	---------------	------	---------	-----------------	------------------	--	--

<b>A11U019</b>	<b>02</b>	<b>OR</b>	<b>N</b>	<b>N</b>	<b>R</b>	<b>B</b>				
----------------	-----------	-----------	----------	----------	----------	----------	--	--	--	--

Pitch 10,16	<b>02</b> = Number of Pos. Standard 2~12 Pos.	<b>GY</b> = Gray (Standard)  <b>GN</b> = Green  <b>OR</b> = Orange  <b>BK</b> = Black	<b>N</b> = No Approval  <b>1</b> = Approval for Material  <b>2</b> = Approval for Terminal Block	<b>N</b> = NON Approval  <b>A</b> = UL /UR Approval Please consult EDCON for available  <b>B</b> = VDE Approval Please consult EDCON for available  <b>C</b> = TÜV Approval Please consult EDCON for available	<b>R</b> = ROHS Conform  <b>N</b> = NON ROHS Conform	<b>B</b> = Standard Package  <b>I</b> = Individual Package	<b>xxxxxx</b> = Customer Number	<b>xxx</b> = Customer Version ??(Printing)		
----------------	--	---	--	--	--	--	---------------------------------	--	--	--

<b>Screwless Terminal Block</b>	
Part No.:	<b>A11U019</b>
Customer:	

DRW:	Jason	CHKD	Wilson	MATL:	Wilson	TOLERANCE	Mason	DATE	10.02.2014
APPD:	Schumi			FINISH	Jamy		Sheet No.		3 from 4



Soldering Profile Curve

Classification Reflow Profile (JEDEC J-STD-020C)

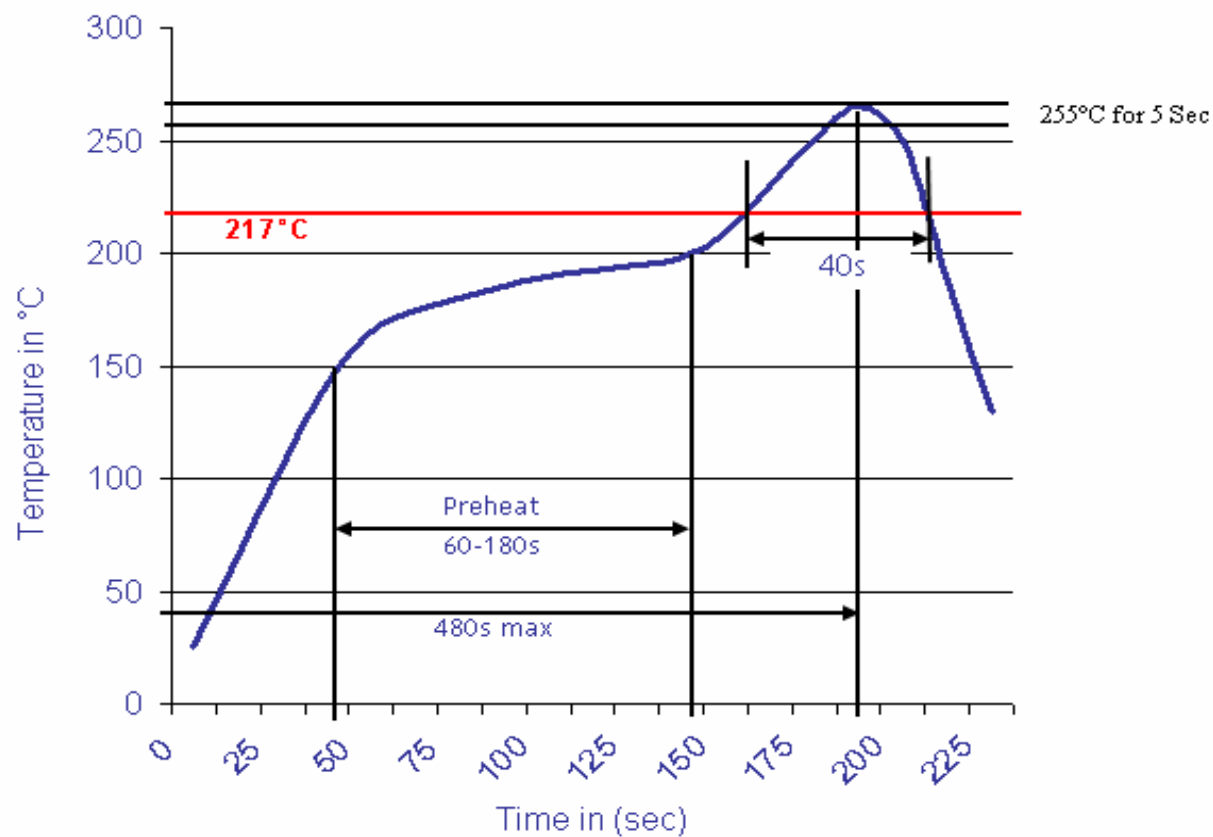

**Screwless Terminal Block**

Part No.: **A11U019**

Customer:

DRW:	Jason	CHKD	Wilson	MATL:	Wilson	TOLERANCE	Mason	DATE	10.02.2014
APPD:	Schumi			FINISH	Jamy		Sheet No.	4 from 4	



