

Data Sheet

Screwless Terminal Block

Pitch: 10,16 mm

Serie: A11U010

Customer Information for special Item

EDCON Customer : 0

Customer Version No. : 0

EDCON-COMPONENTS



Technical Discription

Drawing (Dimension in mm)

Electrical

Standard
 Rated voltage
 Rated current
 Wire range
 Withstanding voltage

UL	IEC
300V	250V, 450V
15A	16A
28-12 AWG	2.5mm ²
AC2000V/1Min	

Mechanical

Wire strip length
 Operating temperature

5 ~ 6mm
 -40°C ~ +105°C

Dimensions

Pitch
 Poles

10.16mm
 1P - xxP

Material

Housing
 Pin header
 Wire guard

PA66 (UL94V-0)
 Phosphor Bronze, Tin plated
 Stainless steel

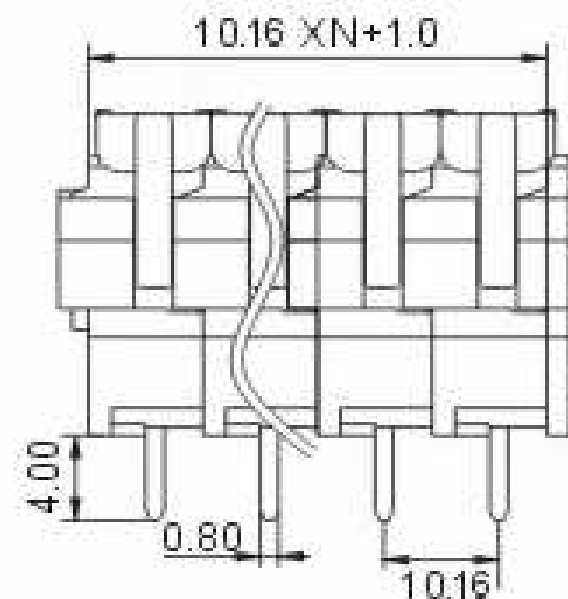
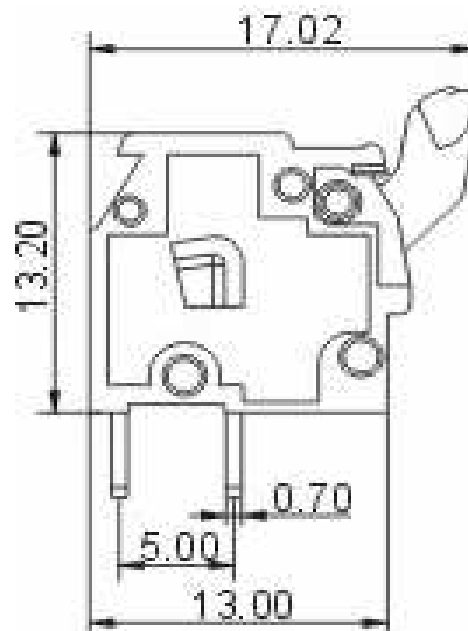

Screwless Terminal Block

Part No.: **A11U010**

Customer:

DRW:	Jason	CHKD	Wilson	MATL:	Wilson	TOLERANCE	Mason	DATE	10.02.2014
APPD:	Schumi			FINISH	Jamy		Sheet No.	1 from 4	

EDCON-COMPONENTS



PCB Layout (Dimension in mm)

Dimensions (mm)

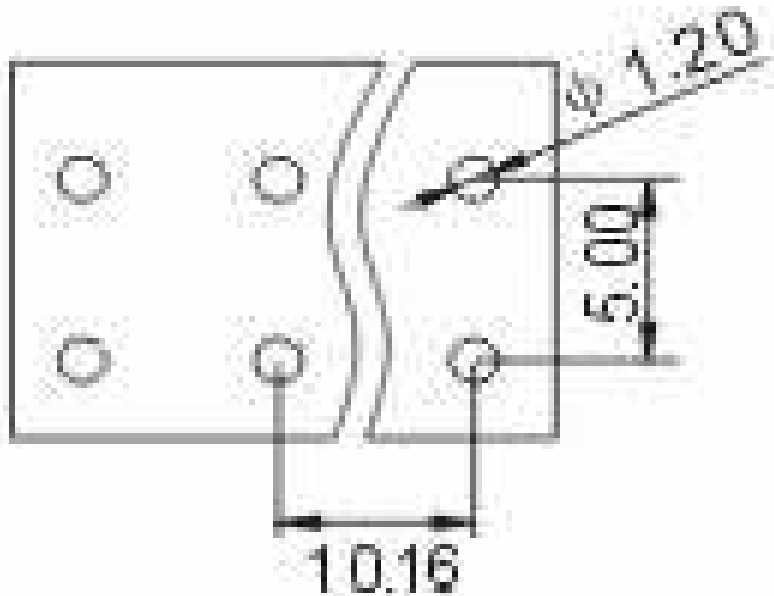

No. of Pos.	A	Tol. P	B	Tol. P	
02	21,32	± 0,35	10,16	± 0,35	
03	31,48	± 0,35	20,32	± 0,35	
04	41,64	± 0,35	30,48	± 0,35	
05	51,80	± 0,35	40,64	± 0,35	
06	61,96	± 0,35	50,80	± 0,35	
07	72,12	± 0,35	60,96	± 0,35	
08	82,28	± 0,35	71,12	± 0,35	
09	92,44	± 0,35	81,28	± 0,35	
10	102,60	± 0,35	91,44	± 0,35	
11	112,76	± 0,35	101,60	± 0,35	
12	122,92	± 0,35	111,76	± 0,35	

Screwless Terminal Block
 Part No.: **A11U010**

DRW:	Jason	CHKD	Wilson	MATL:	Wilson	TOLERANCE	Mason	DATE	10.02.2014	Customer:
APPD:	Schumi			FINISH	Jamy		Sheet No.	2 from 4		

EDCON-COMPONENTS



Ordering Informations

Serie	No. of Pos.	Body Color	Approval	Approval Code	ROHS	Packing	EDCON Cust. No.	Customer Version		
A11U010	02	GY	N	N	R	B				

Pitch
10,16

02= Number of Pos. Standard 2~12 Pos.	GY= Gray (Standard) GN= Green OR= Orange BK= Black	N= No Approval 1= Approval for Material 2= Approval for Terminal Block	N= NON Approval A= UL /UR Approval Please consult EDCON for available B= VDE Approval Please consult EDCON for available C= TÜV Approval Please consult EDCON for available	R= ROHS Conform N= NON ROHS Conform	B= Standard Package I= Individual Package	xxxxxx= Customer Number	xxx= Customer Version ??(Printing)
---	---	---	--	--	--	--------------------------------	---

Screwless Terminal Block

Part No.: **A11U010**

DRW:	Jason	CHKD	Wilson	MATL:	Wilson	TOLERANCE	Mason	DATE	10.02.2014
APPD:	Schumi			FINISH	Jamy		Sheet No.		3 from 4

Customer:



Soldering Profile Curve

Classification Reflow Profile (JEDEC J-STD-020C)



Screwless Terminal Block

Part No.: **A11U010**

Customer:

DRW:	Jason	CHKD	Wilson	MATL:	Wilson	TOLERANCE	Mason	DATE	10.02.2014
APPD:	Schumi			FINISH	Jamy		Sheet No.	4 from 4	

