

Data Sheet

Screwless Terminal Block

Pitch: 10,00 mm

Serie: A11T037

Customer Information for special Item

EDCON Customer : xxxxxx

Customer Version No. : xx

EDCON-COMPONENTS



Technical Discription

Electrical:

Rated voltage:

Rated current:

Withstanding Voltage: AC/1min:

Operating Temperature:

UL	IEC	VDE
300	750	750
12A	16A	16A
2000V	2000V	

-40°C ~ +105°C

Mechanical:

Strip length: mm

Wire range: Solid wire: AWG

Wire range: Stranded wire:AWG

10~11	10~11	
20~12	2,5mm ²	

Material:

Housing Terminal Body:

Housing Left-side:

Housing Right side:

Lever:

Terminal:

Spring Clamp:

PA66 UL94V-0

PA66 UL94V-0

PA66 UL94V-0

PA66 UL94V-0 Orange RAL9003

Copper Matte Tin plated over Nickel

Stainless steel

Drawing (Dimension in mm)

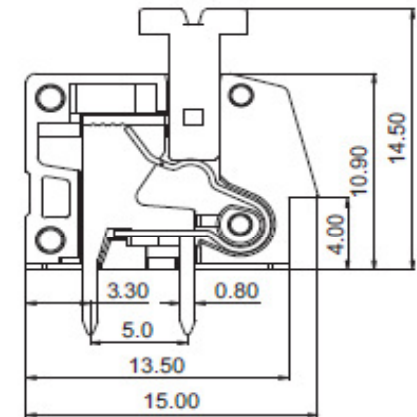
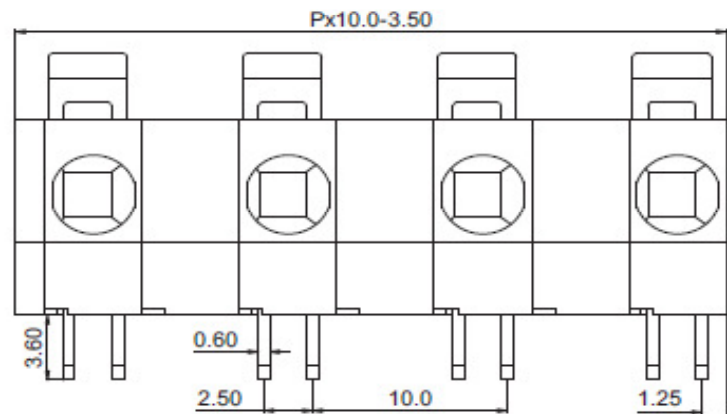

Tolerances unless otherwise specified (mm)

x	x.x	x.xx	x.xxx	Angle
±	±0,1	±0,05	±0,03	±3°

Screwless Terminal Block

Part No.: **A11T037**

Customer:

DRW:	Jason	CHKD	Wilson	MATL:	Wilson	TOLERANCE	Mason	DATE	27.12.2020
APPD:	Schumi			FINISH	Jamy			Sheet No.	1 from 4

www.edcon-components.com

email: info@edcon-components.com

EDCON-COMPONENTS



PCB Layout Dimension (mm)

TOP-VIEW

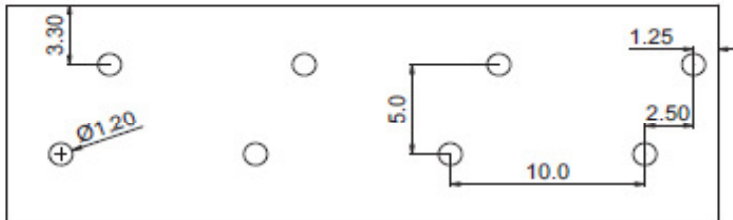

Dimensions (mm)

A	Tol. P	B	Tol. P	No. of Pos.
21,85	± 0,35	10,00	± 0,35	02
31,85	± 0,35	20,00	± 0,35	03
41,85	± 0,35	30,00	± 0,35	04
51,85	± 0,35	40,00	± 0,35	05
61,85	± 0,35	50,00	± 0,35	06
71,85	± 0,35	60,00	± 0,35	07
81,85	± 0,35	70,00	± 0,35	08
91,85	± 0,35	80,00	± 0,35	09
101,85	± 0,35	90,00	± 0,35	10
111,85	± 0,35	100,00	± 0,35	11
121,85	± 0,35	110,00	± 0,35	12
131,85	± 0,35	120,00	± 0,35	13
141,85	± 0,35	130,00	± 0,35	14
151,85	± 0,35	140,00	± 0,35	15
161,85	± 0,35	150,00	± 0,35	16
171,85	± 0,35	160,00	± 0,35	17
181,85	± 0,35	170,00	± 0,35	18
191,85	± 0,35	180,00	± 0,35	19
201,85	± 0,35	190,00	± 0,35	20
211,85	± 0,35	200,00	± 0,35	21
221,85	± 0,35	210,00	± 0,35	22
231,85	± 0,35	220,00	± 0,35	23
241,85	± 0,35	230,00	± 0,35	24

Screwless Terminal Block

Part No.: **A11T037**

Customer:

DRW:	Jason	CHKD	Wilson	MATL:	Wilson	TOLERANCE	Mason	DATE	27.12.2020
APPD:	Schumi			FINISH	Jamy		Sheet No.		2 from 4

www.edcon-components.com

email: info@edcon-components.com

EDCON-COMPONENTS



Ordering Informations

Serie	No. of Pos.	Body Color	Srew Type	Approval Code	ROHS	Packing	EDCON Cust. No.	Customer Version		
A11T037	02	GY	C	N	R	B	xxxxxx	xx		

Pitch
10,00

02= Number of Pos.	GY= Gray (Standard)	C= Screwless Type	N= NON Approval	R= ROHS Conform	B= Standard Package Box/ Polybag	xxxxxx= Customer Number	xx= Customer Version (Printing) ??
Standard 2 ~ 24Pos.			1= UL-Approval for Body Material	N= NON ROHS Conform	I= Individual Package		
			A= UL /UR Approval Please consult EDCON for available				
			B= VDE Approval Please consult EDCON for available				
			C= TÜV Approval Please consult EDCON for available				

Screwless Terminal Block	
Part No.:	A11T037
Customer:	

DRW:	Jason	CHKD	Wilson	MATL:	Wilson	TOLERANCE	Mason	DATE	27.12.2020
APPD:	Schumi			FINISH	Jamy		Sheet No.		3 from 4

www.edcon-components.com

email: info@edcon-components.com



Soldering Profile Curve

Classification Reflow Profile (JEDEC J-STD-020C)

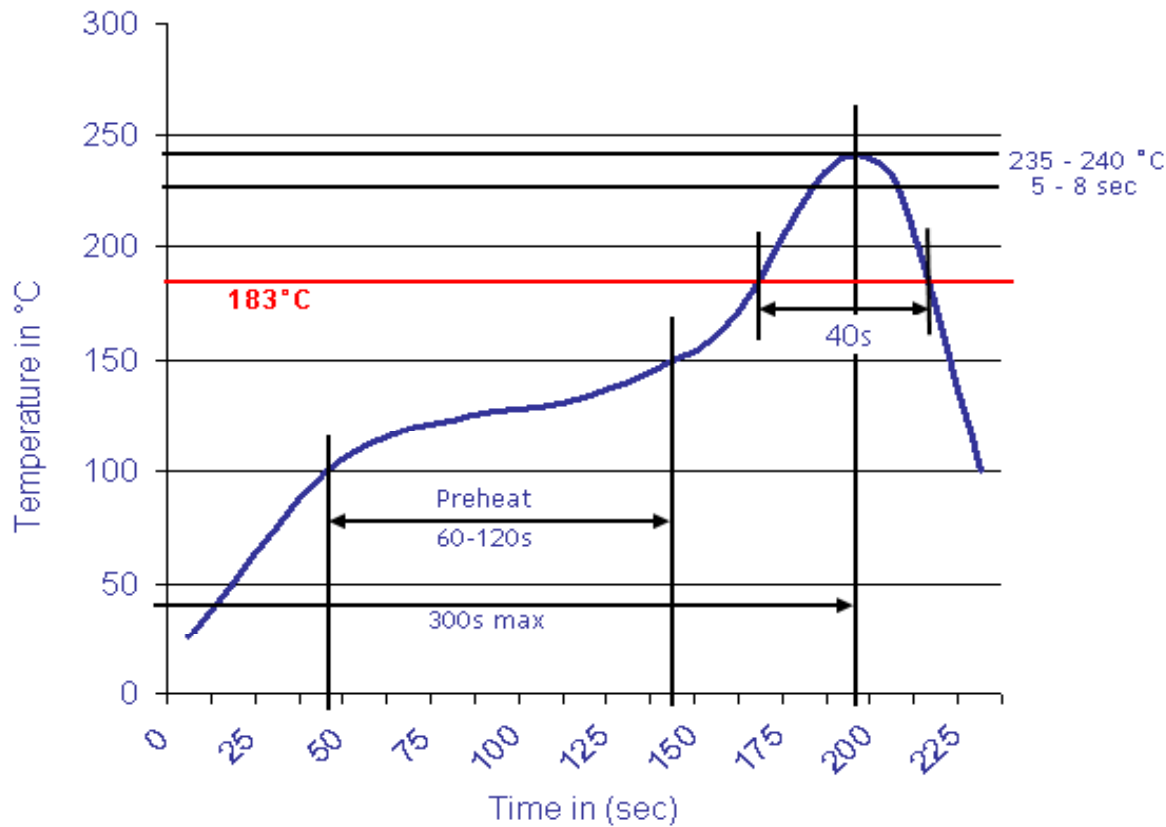

Screwless Terminal Block	
Part No.:	A11T037
Customer:	

DRW:	Jason	CHKD	Wilson	MATL:	Wilson	TOLERANCE	Mason	DATE	27.12.2020
APPD:	Schumi			FINISH	Jamy		Sheet No.	4 from 4	

