

Data Sheet

Screwless Terminal Block

Pitch: 10,00 mm

Serie: A11T022

Customer Information for special Item

EDCON Customer : 0

Customer Version No. : 0

EDCON-COMPONENTS

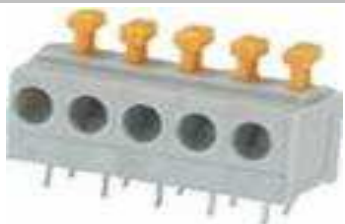

Technical Discription

Drawing (Dimension in mm)

Electrical

Standard UL, VDE
 Rated voltage 300V
 Rated current 12A
 Wire range 20-14 AWG

Mechanical

Operating temperature -40°C ~ +105°C

Dimensions

Pitch 10.00mm
 Poles 2P - 24P

Material

Housing Nylon PA66 (UL94V-0)
 Pin header Brass Tin-plated
 Wire guard Stainless steel

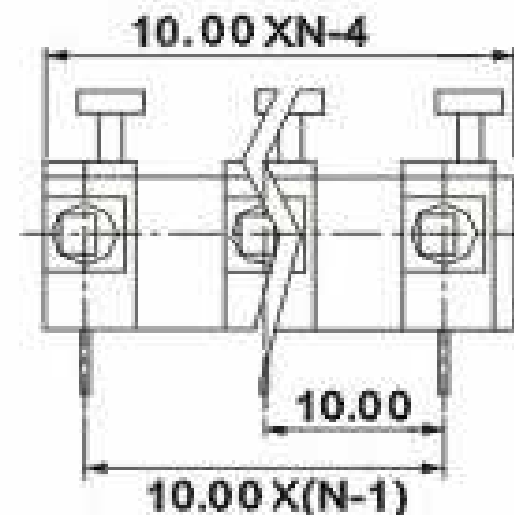
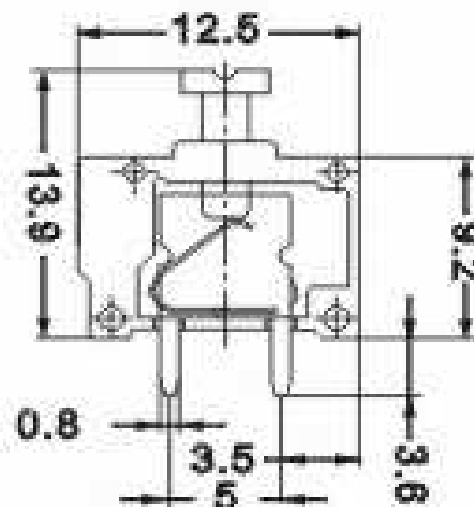

Screwless Terminal Block

Part No.: **A11T022**

Customer:

DRW:	Jason	CHKD	Wilson	MATL:	Wilson	TOLERANCE	Mason	DATE	10.02.2014
APPD:	Schumi			FINISH	Jamy		Sheet No.	1 from 4	

EDCON-COMPONENTS

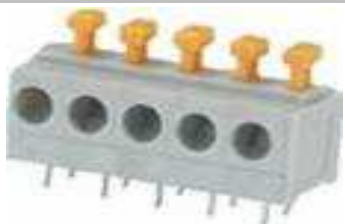

PCB Layout (Dimension in mm)

Dimensions (mm)

No. of Pos.	A	Tol. P	B	Tol. P
02	16,00	± 0,35	10,00	± 0,35
03	26,00	± 0,35	20,00	± 0,35
04	36,00	± 0,35	30,00	± 0,35
05	46,00	± 0,35	40,00	± 0,35
06	56,00	± 0,35	50,00	± 0,35
07	66,00	± 0,35	60,00	± 0,35
08	76,00	± 0,35	70,00	± 0,35
09	86,00	± 0,35	80,00	± 0,35
10	96,00	± 0,35	90,00	± 0,35
11	106,00	± 0,35	100,00	± 0,35
12	116,00	± 0,35	110,00	± 0,35
13	126,00	± 0,35	120,00	± 0,35
14	136,00	± 0,35	130,00	± 0,35
15	146,00	± 0,35	140,00	± 0,35
16	156,00	± 0,35	150,00	± 0,35
17	166,00	± 0,35	160,00	± 0,35
18	176,00	± 0,35	170,00	± 0,35
19	186,00	± 0,35	180,00	± 0,35
20	196,00	± 0,35	190,00	± 0,35
21	206,00	± 0,35	200,00	± 0,35
22	216,00	± 0,35	210,00	± 0,35
23	226,00	± 0,35	220,00	± 0,35
24	236,00	± 0,35	230,00	± 0,35

Screwless Terminal Block

Part No.: **A11T022**

DRW:	Jason	CHKD	Wilson	MATL:	Wilson	TOLERANCE	Mason	DATE	10.02.2014	Customer:
APPD:	Schumi			FINISH	Jamy		Sheet No.	2 from 4		

EDCON-COMPONENTS

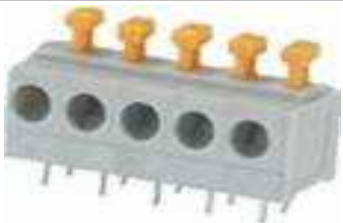

Ordering Informations

Serie	No. of Pos.	Body Color	Approval	Approval Code	ROHS	Packing	EDCON Cust. No.	Customer Version		
-------	-------------	------------	----------	---------------	------	---------	-----------------	------------------	--	--

A11T022	02	GY	N	N	R	B				
----------------	-----------	-----------	----------	----------	----------	----------	--	--	--	--

Pitch 10,00	02 = Number of Pos. Standard 2~24 Pos.	GY = Gray (Standard) GN = Green OR = Orange BK = Black	N = No Approval 1 = Approval for Material 2 = Approval for Terminal Block	N = NON Approval A = UL /UR Approval Please consult EDCON for available B = VDE Approval Please consult EDCON for available C = TÜV Approval Please consult EDCON for available	R = ROHS Conform N = NON ROHS Conform	B = Standard Package I = Individual Package	xxxxxx = Customer Number	xxx = Customer Version ??(Printing)		
----------------	--	---	--	--	--	--	---------------------------------	--	--	--

Screwless Terminal Block

Part No.: **A11T022**

DRW:	Jason	CHKD	Wilson	MATL:	Wilson	TOLERANCE	Mason	DATE	10.02.2014
APPD:	Schumi			FINISH	Jamy			Sheet No.	3 from 4

Customer:

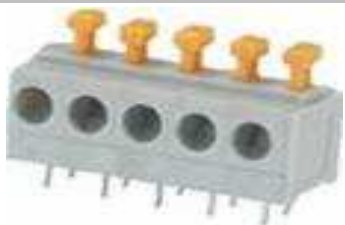

Soldering Profile Curve

Classification Reflow Profile (JEDEC J-STD-020C)

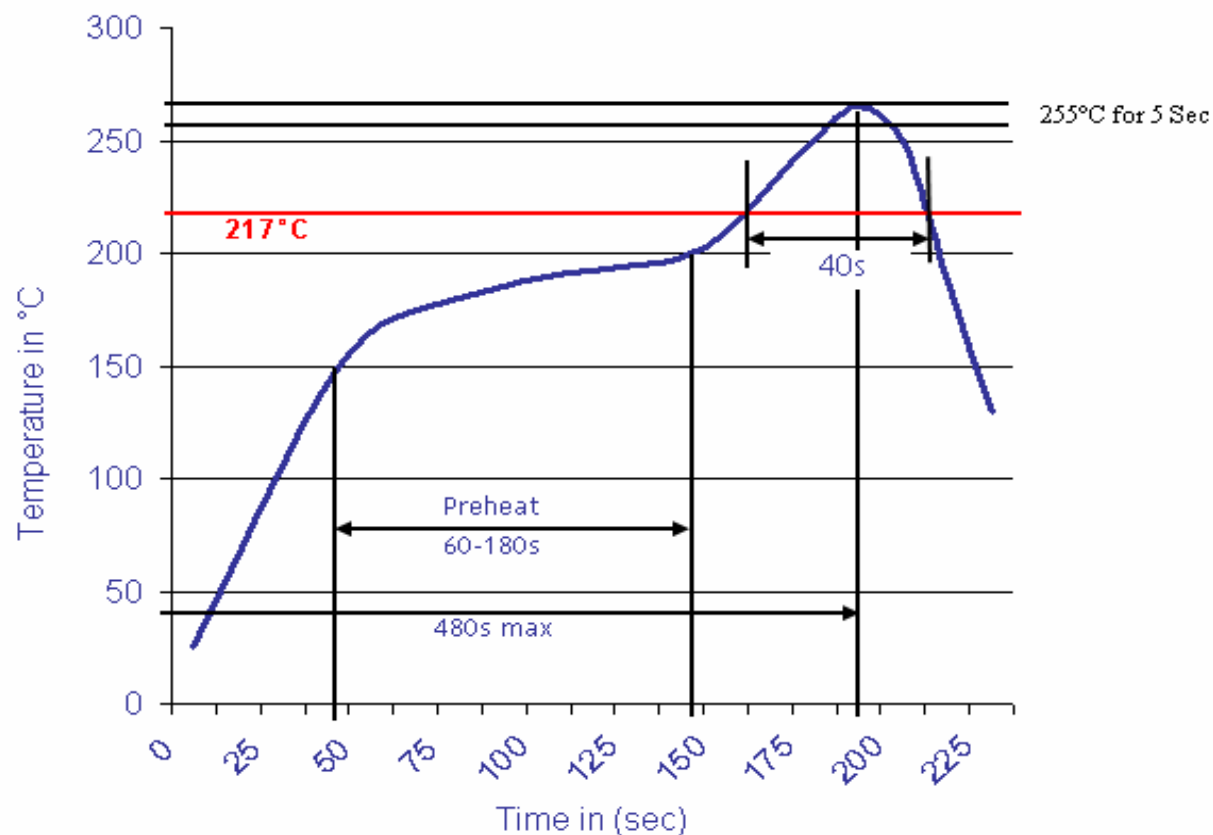

Screwless Terminal Block

Part No.: **A11T022**

Customer:

DRW:	Jason	CHKD	Wilson	MATL:	Wilson	TOLERANCE	Mason	DATE	10.02.2014
APPD:	Schumi			FINISH	Jamy		Sheet No.	4 from 4	

