

# Data Sheet

## Screwless Terminal Block

**Pitch: 10,00 mm**

**Serie: A11T016**

### Customer Information for special Item

**EDCON Customer : 0**

**Customer Version No. : 0**

# EDCON-COMPONENTS



## Technical Description

## Drawing (Dimension in mm)

### Electrical

|                      |              |                    |
|----------------------|--------------|--------------------|
| Standard             | UL           | IEC                |
| Rated voltage        | 300V         | 450V               |
| Rated current        | 30A          | 32A                |
| Wire range           | 24-10 AWG    | 4.0mm <sup>2</sup> |
| Withstanding voltage | AC2000V/1Min |                    |

### Mechanical

|                       |                |
|-----------------------|----------------|
| Wire strip length     | 10mm           |
| Operating temperature | -40°C ~ +105°C |
| Soldering temperature |                |

### Dimensions

|       |          |
|-------|----------|
| Pitch | 10.00mm  |
| Poles | 1P - xxP |

### Material

|            |                             |
|------------|-----------------------------|
| Housing    | PA66 (UL94V-0)              |
| Pin header | Phosphor Bronze, Tin plated |
| Wire guard | Stainless steel             |

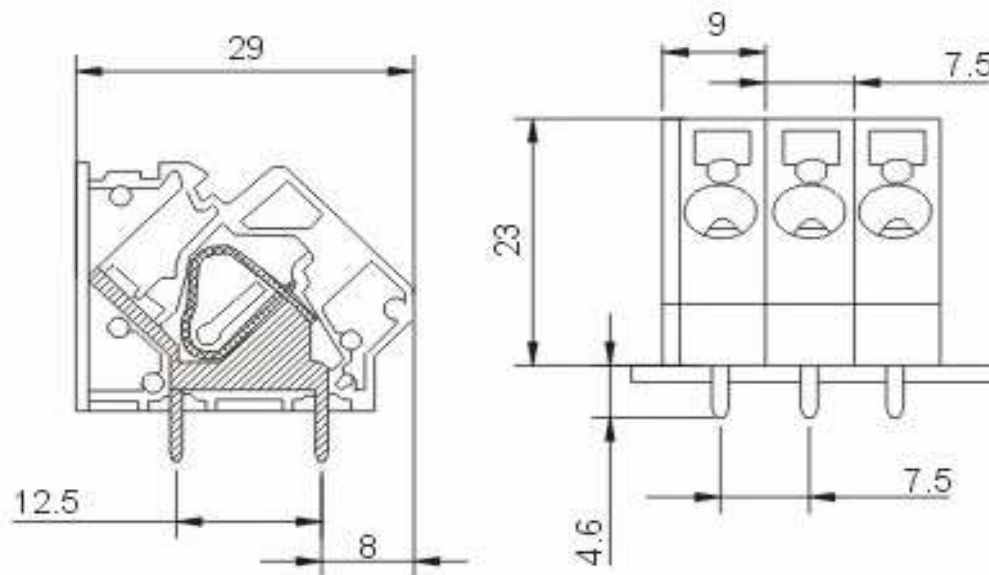

### Screwless Terminal Block

Part No.: **A11T016**

Customer:

|       |        |      |        |        |        |           |           |          |            |
|-------|--------|------|--------|--------|--------|-----------|-----------|----------|------------|
| DRW:  | Jason  | CHKD | Wilson | MATL:  | Wilson | TOLERANCE | Mason     | DATE     | 10.02.2014 |
| APPD: | Schumi |      |        | FINISH | Jamy   |           | Sheet No. | 1 from 4 |            |

# EDCON-COMPONENTS



PCB Layout (Dimension in mm)

Dimensions (mm)

| No. of Pos. | A      | Tol. P | B      | Tol. P |
|-------------|--------|--------|--------|--------|
| 02          | 21,50  | ± 0,35 | 10,00  | ± 0,35 |
| 03          | 31,50  | ± 0,35 | 20,00  | ± 0,35 |
| 04          | 41,50  | ± 0,35 | 30,00  | ± 0,35 |
| 05          | 51,50  | ± 0,35 | 40,00  | ± 0,35 |
| 06          | 61,50  | ± 0,35 | 50,00  | ± 0,35 |
| 07          | 71,50  | ± 0,35 | 60,00  | ± 0,35 |
| 08          | 81,50  | ± 0,35 | 70,00  | ± 0,35 |
| 09          | 91,50  | ± 0,35 | 80,00  | ± 0,35 |
| 10          | 101,50 | ± 0,35 | 90,00  | ± 0,35 |
| 11          | 111,50 | ± 0,35 | 100,00 | ± 0,35 |
| 12          | 121,50 | ± 0,35 | 110,00 | ± 0,35 |
|             |        |        |        |        |
|             |        |        |        |        |
|             |        |        |        |        |
|             |        |        |        |        |
|             |        |        |        |        |
|             |        |        |        |        |
|             |        |        |        |        |
|             |        |        |        |        |
|             |        |        |        |        |
|             |        |        |        |        |
|             |        |        |        |        |
|             |        |        |        |        |
|             |        |        |        |        |
|             |        |        |        |        |
|             |        |        |        |        |
|             |        |        |        |        |
|             |        |        |        |        |
|             |        |        |        |        |

**Screwless Terminal Block**

Part No.: **A11T016**

|       |        |      |        |        |        |           |           |          |            |           |
|-------|--------|------|--------|--------|--------|-----------|-----------|----------|------------|-----------|
| DRW:  | Jason  | CHKD | Wilson | MATL:  | Wilson | TOLERANCE | Mason     | DATE     | 10.02.2014 | Customer: |
| APPD: | Schumi |      |        | FINISH | Jamy   |           | Sheet No. | 2 from 4 |            |           |

# EDCON-COMPONENTS



## Ordering Informations

| Serie | No. of Pos. | Body Color | Approval | Approval Code | ROHS | Packing | EDCON Cust. No. | Customer Version |  |  |
|-------|-------------|------------|----------|---------------|------|---------|-----------------|------------------|--|--|
|-------|-------------|------------|----------|---------------|------|---------|-----------------|------------------|--|--|

|                |           |           |          |          |          |          |  |  |  |  |
|----------------|-----------|-----------|----------|----------|----------|----------|--|--|--|--|
| <b>A11T016</b> | <b>02</b> | <b>GN</b> | <b>N</b> | <b>N</b> | <b>R</b> | <b>B</b> |  |  |  |  |
|----------------|-----------|-----------|----------|----------|----------|----------|--|--|--|--|

|                |  |   |  |  |  |  |                                 |  |  |  |
|----------------|--|---|--|--|--|--|---------------------------------|--|--|--|
| Pitch<br>10,00 | <b>02</b> = Number of Pos.<br>Standard 2~12 Pos. | <b>GY</b> = Gray (Standard)<br><br><b>GN</b> = Green<br><br><b>OR</b> = Orange<br><br><b>BK</b> = Black | <b>N</b> = No Approval<br><br><b>1</b> = Approval for Material<br><br><b>2</b> = Approval for Terminal Block | <b>N</b> = NON Approval<br><br><b>A</b> = UL /UR Approval Please consult EDCON for available<br><br><b>B</b> = VDE Approval Please consult EDCON for available<br><br><b>C</b> = TÜV Approval Please consult EDCON for available | <b>R</b> = ROHS Conform<br><br><b>N</b> = NON ROHS Conform | <b>B</b> = Standard Package<br><br><b>I</b> = Individual Package | <b>xxxxxx</b> = Customer Number | <b>xxx</b> = Customer Version ??(Printing) |  |  |
|----------------|--|---|--|--|--|--|---------------------------------|--|--|--|

**Screwless Terminal Block**

Part No.: **A11T016**

|       |        |      |        |        |        |           |           |      |            |
|-------|--------|------|--------|--------|--------|-----------|-----------|------|------------|
| DRW:  | Jason  | CHKD | Wilson | MATL:  | Wilson | TOLERANCE | Mason     | DATE | 10.02.2014 |
| APPD: | Schumi |      |        | FINISH | Jamy   |           | Sheet No. |      | 3 from 4   |

Customer:



Soldering Profile Curve

Classification Reflow Profile (JEDEC J-STD-020C)



**Screwless Terminal Block**

Part No.: **A11T016**

Customer:

|       |        |      |        |        |        |           |           |          |            |
|-------|--------|------|--------|--------|--------|-----------|-----------|----------|------------|
| DRW:  | Jason  | CHKD | Wilson | MATL:  | Wilson | TOLERANCE | Mason     | DATE     | 10.02.2014 |
| APPD: | Schumi |      |        | FINISH | Jamy   |           | Sheet No. | 4 from 4 |            |



