

# Data Sheet

## Screwless Terminal Block

**Pitch: 10,00 mm**

**Serie: A11T012**

### Customer Information for special Item

**EDCON Customer : 0**

**Customer Version No. : 0**

# EDCON-COMPONENTS

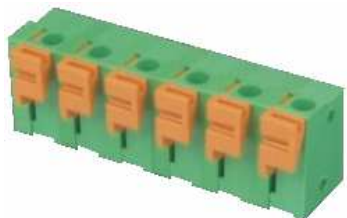

## Technical Discription

## Drawing (Dimension in mm)

### Electrical

Standard  
 Rated voltage  
 Rated current  
 Solid / Stranded wire  
 Withstanding voltage  
 Wire range

cULus	VDE
300V	450V
10A	10A
24-14 AWG	0.75~1.5mm <sup>2</sup>
1.6KV	2.5KV
0.75 ~ 1.5mm <sup>2</sup>	

### Mechanical

Wire strip length  
 Ambient temperature  
 Soldering temperature

6 ~ 7mm  
 -40°C ~ +115°C  
 250°C ±10°C/5 sec

### Dimensions

Pitch  
 Poles

10.00mm  
 2P - 12P

### Material

Housing  
 Pin header  
 Wire guard

Thermoplastic (UL94V-0)  
 Brass, Tin plated  
 Stainless steel

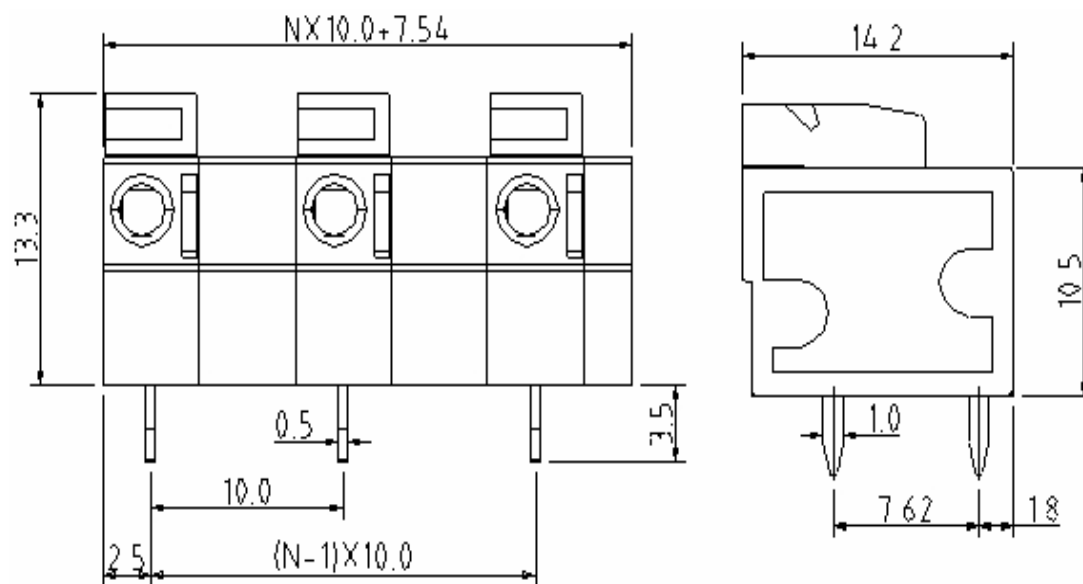

### Screwless Terminal Block

Part No.: **A11T012**

Customer:

DRW:	Jason	CHKD	Wilson	MATL:	Wilson	TOLERANCE	Mason	DATE	07.02.2014
APPD:	Schumi			FINISH	Jamy		Sheet No.	1 from 4	



# EDCON-COMPONENTS

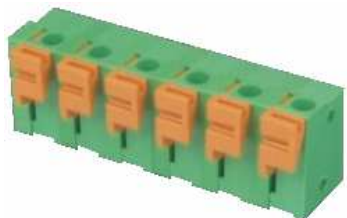

## Ordering Informations

Serie	No. of Pos.	Body Color	Approval	Approval Code	ROHS	Packing	EDCON Cust. No.	Customer Version		
<b>A11T012</b>	<b>02</b>	<b>GN</b>	<b>N</b>	<b>N</b>	<b>R</b>	<b>B</b>				

Pitch  
10,00

<b>02=</b> Number of Pos. Standard 2~12 Pos.	<b>GY=</b> Gray (Standard)	<b>N=</b> No Approval	<b>N=</b> NON Approval	<b>R=</b> ROHS Conform	<b>B=</b> Standard Package	<b>xxxxxx=</b> Customer Number	<b>xxx=</b> Customer Version ??(Printing)
	<b>GN=</b> Green	<b>1=</b> Approval for Material	<b>A=</b> UL /UR Approval Please consult EDCON for available	<b>N=</b> NON ROHS Conform	<b>I=</b> Individual Package		
		<b>2=</b> Approval for Terminal Block	<b>B=</b> VDE Approval Please consult EDCON for available				
	<b>OR=</b> Orange		<b>C=</b> TÜV Approval Please consult EDCON for available				
	<b>BK=</b> Black						

<b>Screwless Terminal Block</b>	
Part No.:	<b>A11T012</b>
Customer:	

DRW:	Jason	CHKD	Wilson	MATL:	Wilson	TOLERANCE	Mason	DATE	07.02.2014
APPD:	Schumi			FINISH	Jamy		Sheet No.		3 from 4

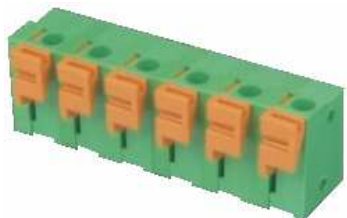

Soldering Profile Curve

Classification Reflow Profile (JEDEC J-STD-020C)

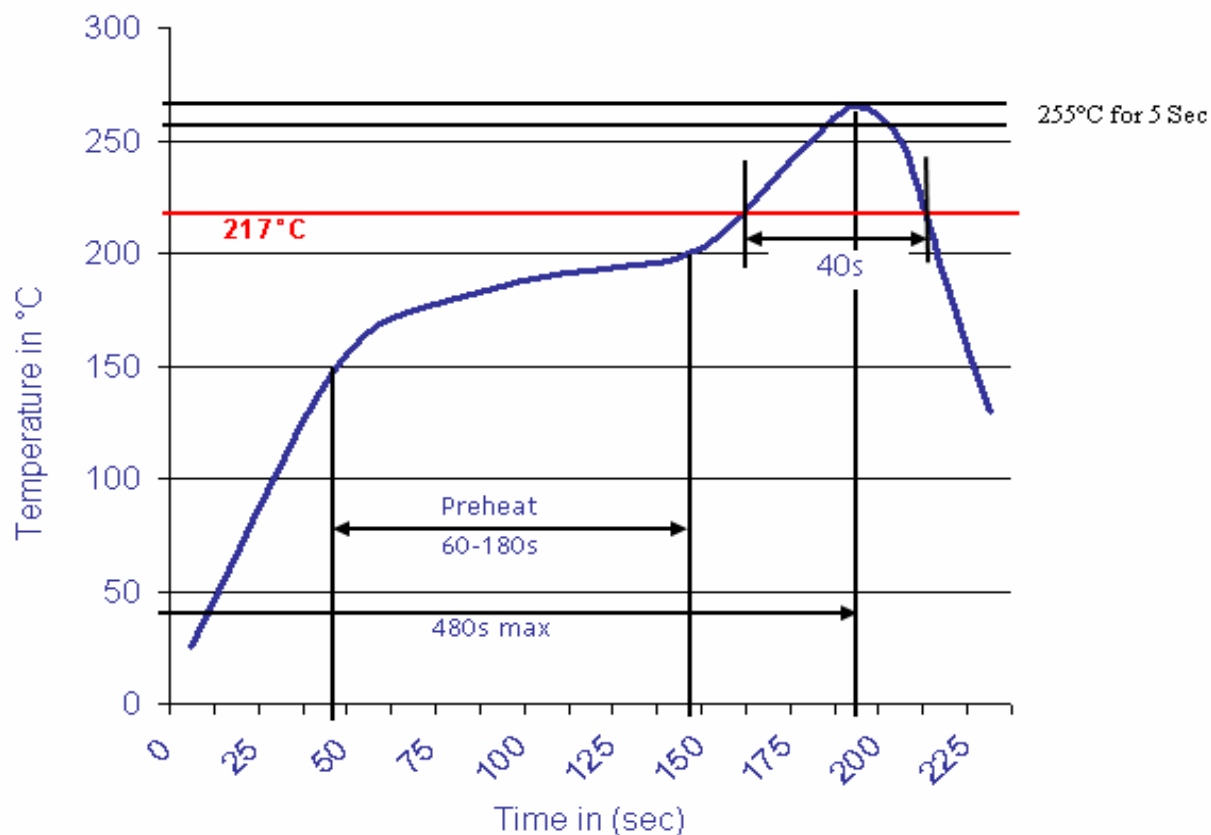

**Screwless Terminal Block**

Part No.: **A11T012**

Customer:

DRW:	Jason	CHKD	Wilson	MATL:	Wilson	TOLERANCE	Mason	DATE	07.02.2014
APPD:	Schumi			FINISH	Jamy		Sheet No.	4 from 4	



