

Data Sheet

Screwless Terminal Block

Pitch: 10,00 mm

Serie: A11T011

Customer Information for special Item

EDCON Customer : 0

Customer Version No. : 0

EDCON-COMPONENTS

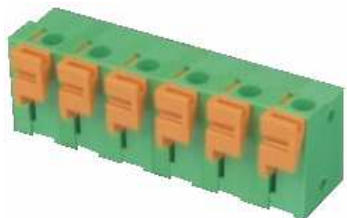

Technical Description

Drawing (Dimension in mm)

Electrical

Standard
 Rated voltage
 Rated current
 Solid / Stranded wire
 Withstanding voltage
 Wire range

cULus	VDE
300V	450V
10A	10A
24-14 AWG	0.75~1.5mm ²
1.6KV	2.5KV
0.75 ~ 1.5mm ²	

Mechanical

Wire strip length
 Ambient temperature
 Soldering temperature

6 ~ 7mm
 -40°C ~ +115°C
 250°C ±10°C/5 sec

Dimensions

Pitch
 Poles

10.00mm
 2P - 12P

Material

Housing
 Pin header
 Wire guard

Thermoplastic (UL94V-0)
 Brass, Tin plated
 Stainless steel

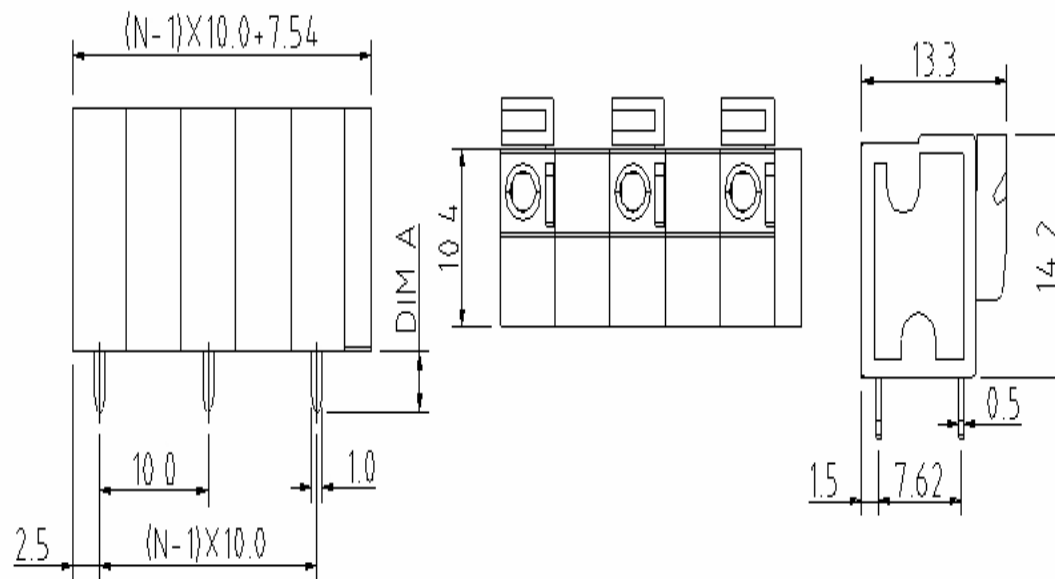

Screwless Terminal Block

Part No.: **A11T011**

Customer:

DRW:	Jason	CHKD	Wilson	MATL:	Wilson	TOLERANCE	Mason	DATE	07.02.2014
APPD:	Schumi			FINISH	Jamy		Sheet No.	1 from 4	

EDCON-COMPONENTS

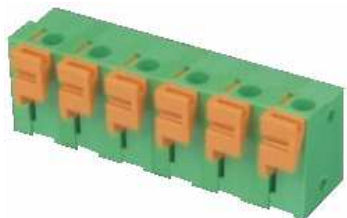

PCB Layout (Dimension in mm)

Dimensions (mm)

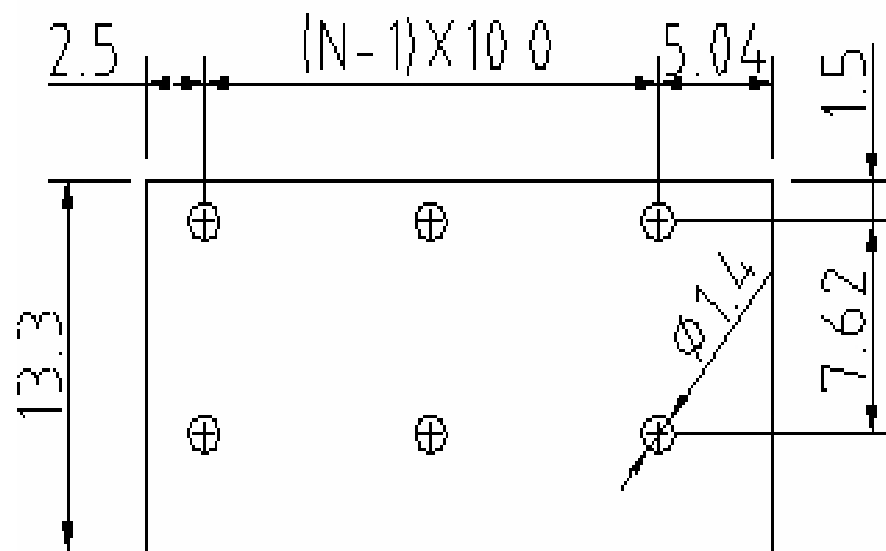

No. of Pos.	A	Tol. P	B	Tol. P
02	27,54	± 0,35	10,00	± 0,35
03	37,54	± 0,35	20,00	± 0,35
04	47,54	± 0,35	30,00	± 0,35
05	57,54	± 0,35	40,00	± 0,35
06	67,54	± 0,35	50,00	± 0,35
07	77,54	± 0,35	60,00	± 0,35
08	87,54	± 0,35	70,00	± 0,35
09	97,54	± 0,35	80,00	± 0,35
10	107,54	± 0,35	90,00	± 0,35
11	117,54	± 0,35	100,00	± 0,35
12	127,54	± 0,35	110,00	± 0,35

Screwless Terminal Block

Part No.: **A11T011**

DRW:	Jason	CHKD	Wilson	MATL:	Wilson	TOLERANCE	Mason	DATE	07.02.2014
APPD:	Schumi			FINISH	Jamy		Sheet No.	2	from 4

Customer:

EDCON-COMPONENTS

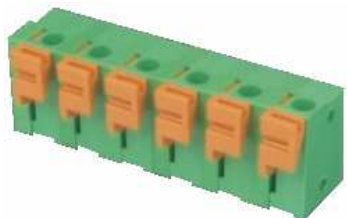

Ordering Informations

Serie	No. of Pos.	Body Color	Approval	Approval Code	ROHS	Packing	EDCON Cust. No.	Customer Version		
A11T011	02	GN	N	N	R	B				

Pitch:
10,00

02= Number of Pos. Standard 2~12 Pos.	GY= Gray (Standard)	N= No Approval	N= NON Approval	R= ROHS Conform	B= Standard Package	xxxxxx= Customer Number	xxx= Customer Version ??(Printing)
	GN= Green	1= Approval for Material	A= UL /UR Approval Please consult EDCON for available	N= NON ROHS Conform	I= Individual Package		
		2= Approval for Terminal Block	B= VDE Approval Please consult EDCON for available				
	OR= Orange		C= TÜV Approval Please consult EDCON for available				
	BK= Black						

Screwless Terminal Block	
Part No.:	A11T011
Customer:	

DRW:	Jason	CHKD	Wilson	MATL:	Wilson	TOLERANCE	Mason	DATE	07.02.2014
APPD:	Schumi			FINISH	Jamy		Sheet No.		3 from 4

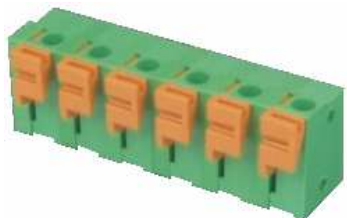

Soldering Profile Curve

Classification Reflow Profile (JEDEC J-STD-020C)



Screwless Terminal Block

Part No.: **A11T011**

Customer:

DRW:	Jason	CHKD	Wilson	MATL:	Wilson	TOLERANCE	Mason	DATE	07.02.2014
APPD:	Schumi			FINISH	Jamy		Sheet No.	4 from 4	

