

Data Sheet

Screwless Terminal Block Pitch 7,62mm

Pitch: 7,62 mm

Serie: A11R036

Customer Information for special Item

EDCON Customer : xxxxxx

Customer Version No. : xx

EDCON-COMPONENTS

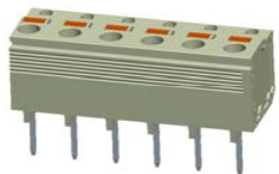

Technical Discription

Electrical:

Rated voltage:

Rated current:

Withstanding Voltage: AC/1min:

Operating Temperature:

UL	IEC	VDE
300V	400V	
20A	12A	
2000V	2000V	

-40°C ~ +105°C

Mechanical:

Strip length: mm

Wire range: Solid wire: AWG

Wire range: Stranded wire:AWG

9~10mm	9~10mm	
28~12	2,5mm ²	

Material:

Housing Terminal Body:

Housing Left-side:

Housing Right side:

Lever:

Terminal:

Spring Clamp:

PA66 UL94V-0

PA66 UL94V-0

PA66 UL94V-0

Copper Matte Tin plated over Nickel

Stainless steel

Drawing (Dimension in mm)

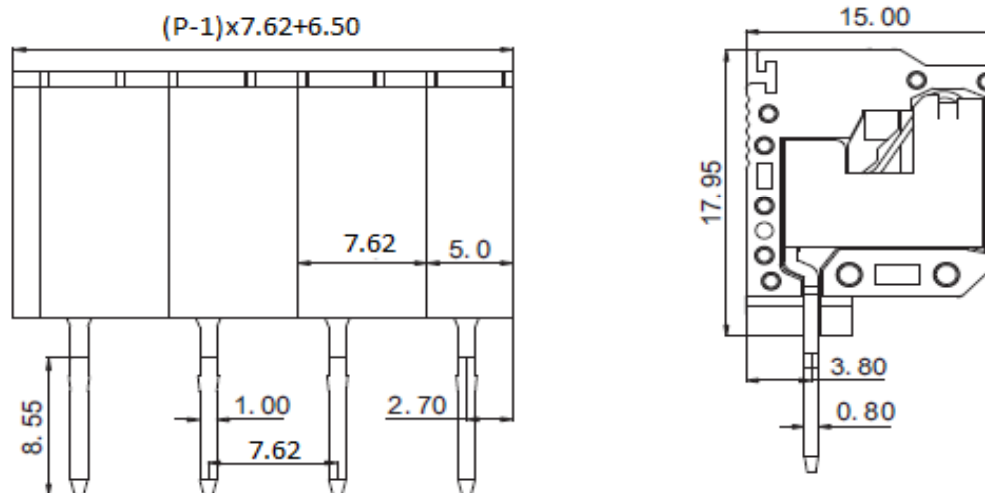

Item No.		
1		
2		
3		
4		
5		
6		
7		
8		
9		

Tolerances unless otherwise specified (mm)				
X	X.X	X.XX	X.XXX	Angle
±	±	±	±	±3°
DRW:	Jason	CHKD	Wilson	MATL:
APPD:	Schumi			FINISH

Screwless Terminal Block Pitch 7,62mm	
Part No.:	A11R036
Customer:	

DRW:	Jason	CHKD	Wilson	MATL:	Wilson	TOLERANCE	Mason	DATE	30.11.2020
APPD:	Schumi			FINISH	Jamy			Sheet No.	1 from 4

EDCON-COMPONENTS

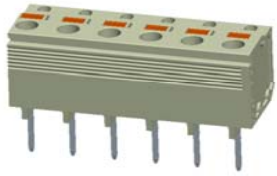

PCB Layout Dimension (mm)
TOP-VIEW

Dimensions (mm)

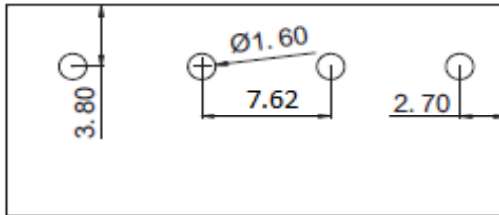

Frontside

**Screwless Terminal Block Pitch
7,62mm**

Part No.: **A11R036**

DRW:	Jason	CHKD	Wilson	MATL:	Wilson	TOLERANCE	Mason	DATE	30.11.2020
APPD:	Schumi			FINISH	Jamy		Sheet No.	2 from 4	Customer:

www.edcon-components.com

email: info@edcon-components.com

EDCON-COMPONENTS



Ordering Informations

Serie	No. of Pos.	Body Color	Srew Type	Approval Code	ROHS	Packing	EDCON Cust. No.	Customer Version		
A11R036	02	GY	C	N	R	B	xxxxxx	xx		

Pitch
7,62

02= Number of Pos.	GY= Gray (Standard)	C= Screwless Type	N= NON Approval	R= ROHS Conform	B= Standard Package Box/ Polybag	xxxxxx= Customer Number	xx= Customer Version (Printing) ??
Standard 2 ~ 16Pos.			1= UL-Approval for Body Material	N= NON ROHS Conform	I= Individual Package		
			A= UL /UR Approval Please consult EDCON for available				
			B= VDE Approval Please consult EDCON for available				
			C= TÜV Approval Please consult EDCON for available				

Screwless Terminal Block Pitch	
7,62mm	
Part No.:	A11R036
Customer:	

DRW:	Jason	CHKD	Wilson	MATL:	Wilson	TOLERANCE	Mason	DATE	30.11.2020
APPD:	Schumi			FINISH	Jamy		Sheet No.		3 from 4

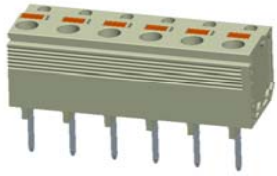

Soldering Profile Curve

Classification Reflow Profile (JEDEC J-STD-020C)

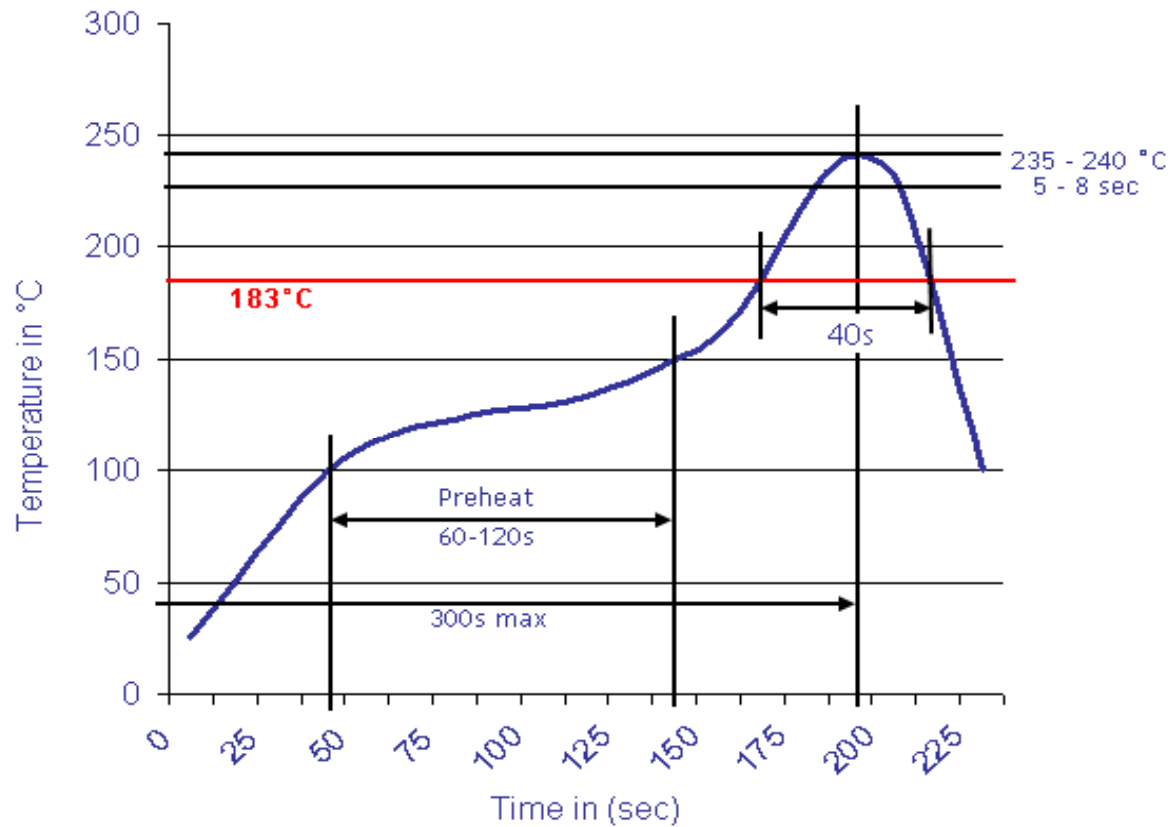

Screwless Terminal Block Pitch 7,62mm	
Part No.:	A11R036
Customer:	

DRW:	Jason	CHKD	Wilson	MATL:	Wilson	TOLERANCE	Mason	DATE	30.11.2020
APPD:	Schumi			FINISH	Jamy		Sheet No.	4 from 4	