

# Data Sheet

## Screwless Terminal Block Pitch 7,62mm

**Pitch: 7,62 mm**

**Serie: A11R34**

### Customer Information for special Item

**EDCON Customer : xxxxxx**

**Customer Version No. : xx**

# EDCON-COMPONENTS



## Technical Description

### Electrical:

Rated voltage:

Rated current:

Withstanding Voltage: AC/1min:

Operating Temperature:

### Mechanical:

Strip length: mm

Wire range: Solid wire: AWG

Wire range: Stranded wire: AWG

### Material:

Housing Terminal Body:

Housing Left-side:

Housing Right side:

Lever:

Terminal:

Spring Clamp:

UL	IEC	VDE
300V	450V	
0A	10A	
2000V	2000V	

-40°C ~ +105°C

10~11mm	10~11mm	
22~15	1,5mm <sup>2</sup>	

PA66 UL94V-0

PA66 UL94V-0

PA66 UL94V-0

Copper Matte Tin plated over Nickel

Stainless steel

## Drawing (Dimension in mm)

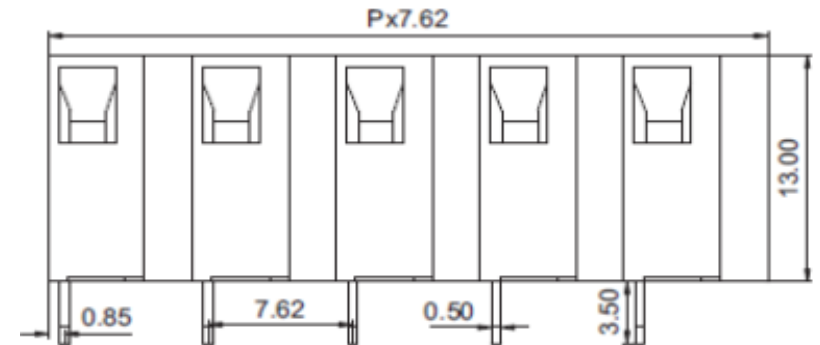
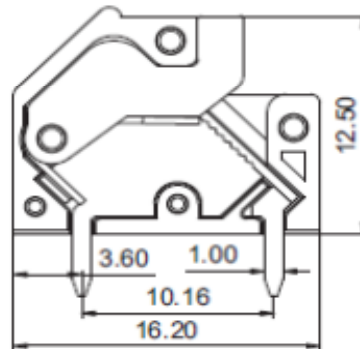

Item No.		
1		
2		
3		
4		
5		
6		
7		
8		
9		

Tolerances unless otherwise specified (mm)				
X	X.X	X.XX	X.XXX	Angle
±	±	±	±	±3°
DRW:	Jason	CHKD	Wilson	MATL:
APPD:	Schumi			FINISH

**Screwless Terminal Block Pitch  
7,62mm**

Part No.: **A11R34**

Customer:

DRW:	Jason	CHKD	Wilson	MATL:	Wilson	TOLERANCE	Mason	DATE	30.11.2020
APPD:	Schumi			FINISH	Jamy			Sheet No.	1 from 4

[www.edcon-components.com](http://www.edcon-components.com)

email: [info@edcon-components.com](mailto:info@edcon-components.com)

# EDCON-COMPONENTS



**PCB Layout Dimension (mm)**  
TOP-VIEW

**Dimensions (mm)**

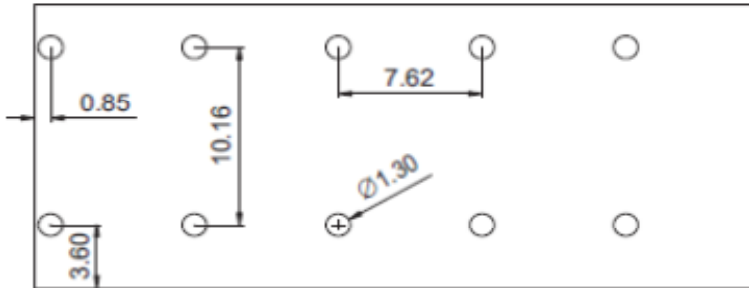

Frontside

**Screwless Terminal Block Pitch  
7,62mm**

Part No.: **A11R34**

DRW:	Jason	CHKD	Wilson	MATL:	Wilson	TOLERANCE	Mason	DATE	30.11.2020
APPD:	Schumi			FINISH	Jamy		Sheet No.	2 from 4	

Customer:

# EDCON-COMPONENTS



EDCON EDCON EDCON



## Ordering Informations

Serie	No. of Pos.	Body Color	Srew Type	Approval Code	ROHS	Packing	EDCON Cust. No.	Customer Version		
<b>A11R34</b>	<b>02</b>	<b>PG</b>	<b>C</b>	<b>N</b>	<b>R</b>	<b>B</b>	<b>xxxxxx</b>	<b>xx</b>		

Pitch
7,62

<b>02=</b> Number of Pos.		<b>C=</b> Screwless Type	<b>N=</b> NON Approval	<b>R=</b> ROHS Conform	<b>B=</b> Standard Package Box/ Polybag	<b>xxxxxx=</b> Customer Number	<b>xx=</b> Customer Version (Printing) ??
Standard 2 ~ 16Pos.			<b>1=</b> UL-Approval for Body Material	<b>N=</b> NON ROHS Conform	<b>I=</b> Individual Package		
			<b>A=</b> UL /UR Approval Please consult EDCON for available				
			<b>B=</b> VDE Approval Please consult EDCON for available				
			<b>C=</b> TÜV Approval Please consult EDCON for available				
		<b>PG=</b> Phoenix Green					

<b>Screwless Terminal Block Pitch</b>	
<b>7,62mm</b>	
Part No.:	<b>A11R34</b>
Customer:	

DRW:	Jason	CHKD	Wilson	MATL:	Wilson	TOLERANCE	Mason	DATE	30.11.2020
APPD:	Schumi			FINISH	Jamy		Sheet No.		3 from 4



Soldering Profile Curve

Classification Reflow Profile (JEDEC J-STD-020C)

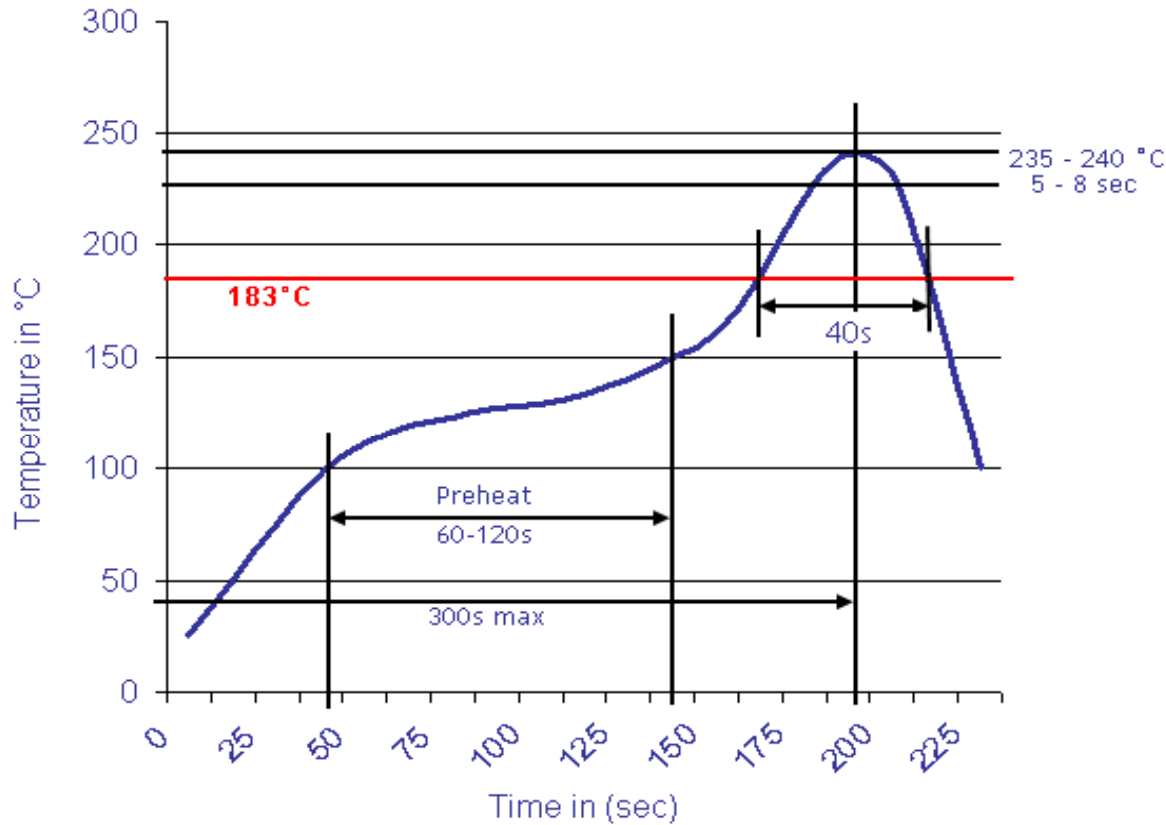

<b>Screwless Terminal Block Pitch 7,62mm</b>	
Part No.:	<b>A11R34</b>
Customer:	

DRW:	Jason	CHKD	Wilson	MATL:	Wilson	TOLERANCE	Mason	DATE	30.11.2020
APPD:	Schumi			FINISH	Jamy		Sheet No.		4 from 4