

# Data Sheet

## Screwless Terminal Block

**Pitch: 7,62 mm**

**Serie: A11R020**

### Customer Information for special Item

**EDCON Customer : 0**

**Customer Version No. : 0**

# EDCON-COMPONENTS

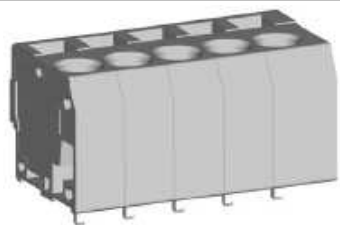

## Technical Discription

## Drawing (Dimension in mm)

### Electrical

Standard	cULus
Rated voltage	300V
Rated current	8A
Withstanding voltage	1.5KV
Solid / Stranded wire	28-12 AWG

### Mechanical

Wire strip length	6 ~ 7mm
Ambient temperature	-40°C ~ +115°C
Soldering temperature	250°C ±10°C/5 sec

### Dimensions

Pitch	7.62mm
Poles	2P - 12P

### Material

Housing	Thermoplastic (UL94V-0)
Pin header	Brass, Tin plated
Wire guard	Stainless steel

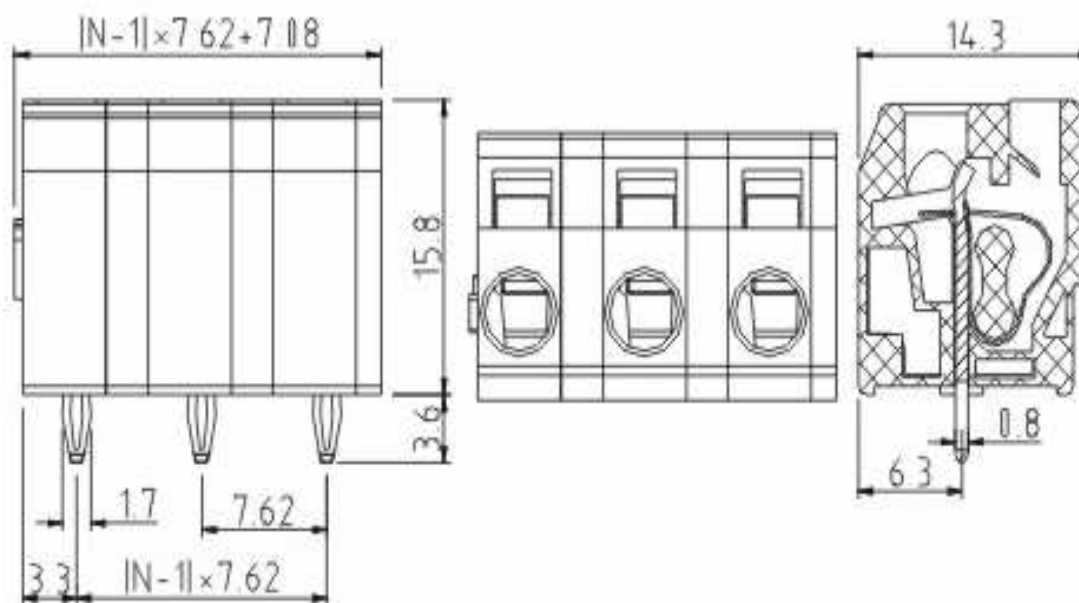

### Screwless Terminal Block

Part No.: **A11R020**

Customer:

DRW:	Jason	CHKD	Wilson	MATL:	Wilson	TOLERANCE	Mason	DATE	07.02.2014
APPD:	Schumi			FINISH	Jamy		Sheet No.	1 from 4	



# EDCON-COMPONENTS

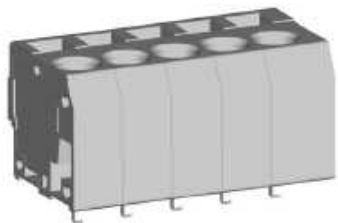

## Ordering Informations

Serie	No. of Pos.	Body Color	Approval	Approval Code	ROHS	Packing	EDCON Cust. No.	Customer Version		
-------	-------------	------------	----------	---------------	------	---------	-----------------	------------------	--	--

<b>A11R020</b>	<b>02</b>	<b>GY</b>	<b>N</b>	<b>N</b>	<b>R</b>	<b>B</b>				
----------------	-----------	-----------	----------	----------	----------	----------	--	--	--	--

Pitch	02= Number of Pos.	GY= Gray (Standard)	N= No Approval	N= NON Approval	R= ROHS Conform	B= Standard Package	xxxxxx= Customer Number	xxx= Customer Version ??(Printing)
7,62	Standard 2~12 Pos.		1= Approval for Material	A= UL /UR Approval Please consult EDCON for available	N= NON ROHS Conform	I= Individual Package		
		GN= Green	2= Approval for Terminal Block	B= VDE Approval Please consult EDCON for available				
		OR= Orange		C= TÜV Approval Please consult EDCON for available				
		BK= Black						

**Screwless Terminal Block**

Part No.: **A11R020**

DRW:	Jason	CHKD	Wilson	MATL:	Wilson	TOLERANCE	Mason	DATE	07.02.2014
APPD:	Schumi			FINISH	Jamy		Sheet No.		3 from 4

Customer:

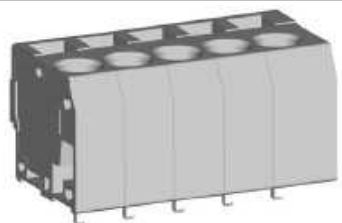

Soldering Profile Curve

Classification Reflow Profile (JEDEC J-STD-020C)



**Screwless Terminal Block**

Part No.: **A11R020**

Customer:

DRW:	Jason	CHKD	Wilson	MATL:	Wilson	TOLERANCE	Mason	DATE	07.02.2014
APPD:	Schumi			FINISH	Jamy		Sheet No.	4 from 4	



