

# Data Sheet

## Screwless Terminal Block

**Pitch: 7,62 mm**

**Serie: A11R012**

### Customer Information for special Item

**EDCON Customer : 0**

**Customer Version No. : 0**

# EDCON-COMPONENTS



## Technical Discription

## Drawing (Dimension in mm)

### Electrical

Standard  
 Rated voltage  
 Rated current  
 Wire range  
 Withstanding voltage

UL	IEC
300V	250V
10A	15A
22-14 AWG	1.5mm <sup>2</sup>
AC2000V/1Min	

### Mechanical

Wire strip length  
 Operating temperature

10mm  
 -40°C ~ +105°C

### Dimensions

Pitch  
 Poles

7.62mm  
 1P - xxP

### Material

Housing  
 Pin header  
 Wire guard

PA66 (UL94V-0)  
 Brass, Tin plated  
 Stainless steel

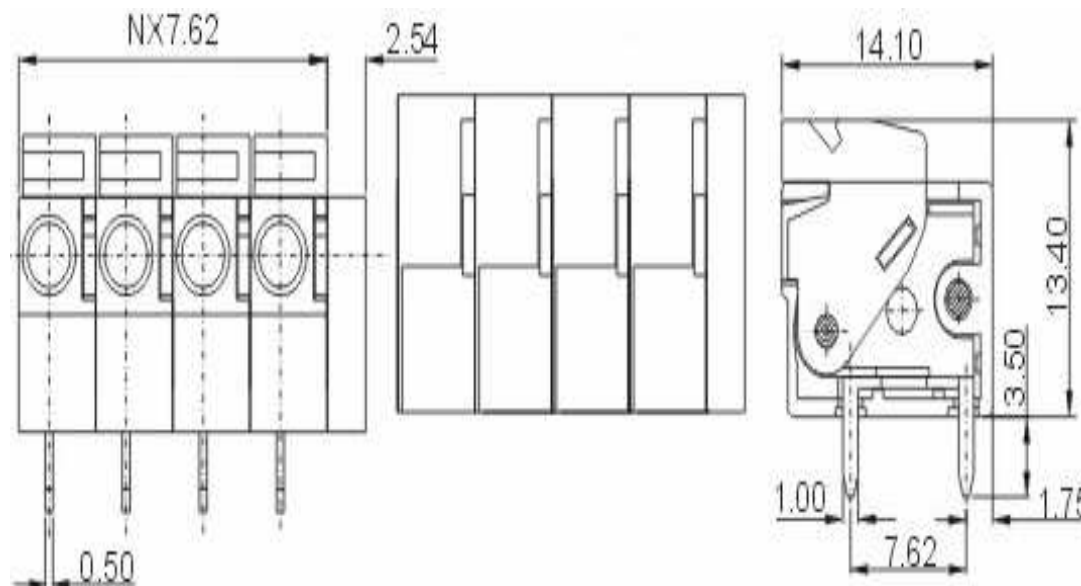

### Screwless Terminal Block

Part No.: **A11R012**

Customer:

DRW:	Jason	CHKD	Wilson	MATL:	Wilson	TOLERANCE	Mason	DATE	07.02.2014
APPD:	Schumi			FINISH	Jamy		Sheet No.	1 from 4	



# EDCON-COMPONENTS



## Ordering Informations

Serie	No. of Pos.	Body Color	Approval	Approval Code	ROHS	Packing	EDCON Cust. No.	Customer Version		
-------	-------------	------------	----------	---------------	------	---------	-----------------	------------------	--	--

<b>A11R012</b>	<b>02</b>	<b>GN</b>	<b>N</b>	<b>N</b>	<b>R</b>	<b>B</b>				
----------------	-----------	-----------	----------	----------	----------	----------	--	--	--	--

Pitch	02= Number of Pos.	GY= Gray (Standard)	N= No Approval	N= NON Approval	R= ROHS Conform	B= Standard Package	xxxxxx= Customer Number	xxx= Customer Version ??(Printing)
-------	--------------------	---------------------	----------------	-----------------	-----------------	---------------------	-------------------------	------------------------------------

Standard 2~12 Pos.			1= Approval for Material	A= UL /UR Approval Please consult EDCON for available	N= NON ROHS Conform	I= Individual Package		
	GN= Green		2= Approval for Terminal Block					
				B= VDE Approval Please consult EDCON for available				
	OR= Orange							
	BK= Black			C= TÜV Approval Please consult EDCON for available				

<b>Screwless Terminal Block</b>	
Part No.:	<b>A11R012</b>
Customer:	

DRW:	Jason	CHKD	Wilson	MATL:	Wilson	TOLERANCE	Mason	DATE	07.02.2014
APPD:	Schumi			FINISH	Jamy		Sheet No.		3 from 4



Soldering Profile Curve

Classification Reflow Profile (JEDEC J-STD-020C)



**Screwless Terminal Block**

Part No.: **A11R012**

Customer:

DRW:	Jason	CHKD	Wilson	MATL:	Wilson	TOLERANCE	Mason	DATE	07.02.2014
APPD:	Schumi			FINISH	Jamy		Sheet No.	4 from 4	



