

# Data Sheet

## Screwless Terminal Block

**Pitch: 7,62 mm**

**Serie: A11R010**

### Customer Information for special Item

**EDCON Customer : 0**

**Customer Version No. : 0**

# EDCON-COMPONENTS

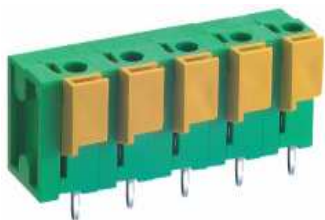

## Technical Discription

## Drawing (Dimension in mm)

### Electrical

Standard  
Rated voltage  
Rated current  
Wire range

cUL	VDE
AC 300V	AC 450V
10A	16A
24-14 AWG	0.2-2.5mm <sup>2</sup>

### Mechanical

Operating temperature

-40°C ~ +105°C

### Dimensions

Pitch  
Poles

7.62mm  
2P - 16P

### Material

Housing  
Pin header  
Wire guard

Polyamide66 (UL94V-0)  
Brass, Tin plated  
Stainless steel

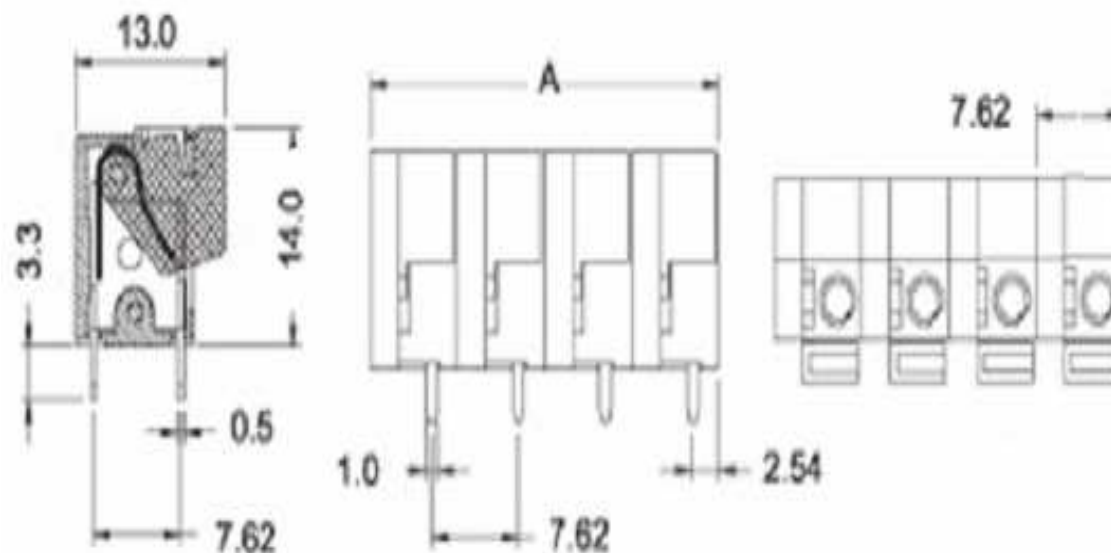

### Screwless Terminal Block

Part No.: **A11R010**

Customer:

DRW:	Jason	CHKD	Wilson	MATL:	Wilson	TOLERANCE	Mason	DATE	07.02.2014
APPD:	Schumi			FINISH	Jamy		Sheet No.	1 from 4	

# EDCON-COMPONENTS

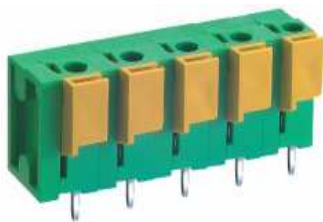

PCB Layout (Dimension in mm)

Dimensions (mm)

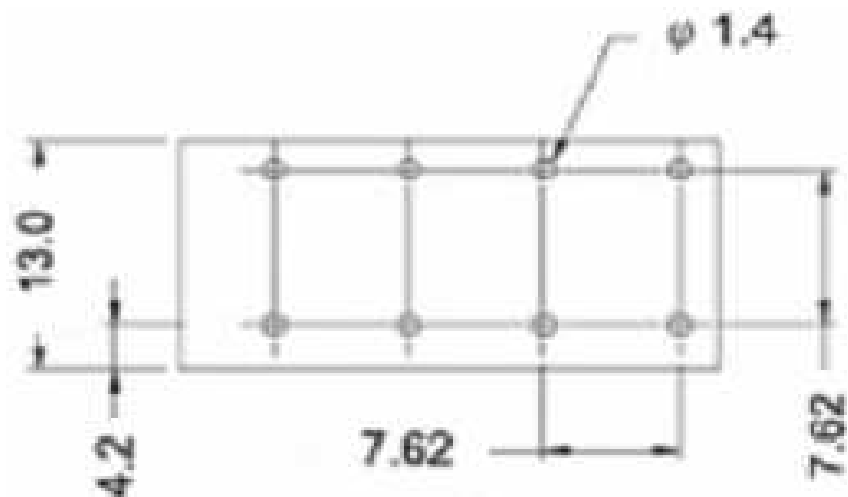

No. of Pos.	A	Tol. P	B	Tol. P	
02	15,24	± 0,35	7,62	± 0,35	
03	22,86	± 0,35	15,24	± 0,35	
04	30,48	± 0,35	22,86	± 0,35	
05	38,10	± 0,35	30,48	± 0,35	
06	45,72	± 0,35	38,10	± 0,35	
07	53,34	± 0,35	45,72	± 0,35	
08	60,96	± 0,35	53,34	± 0,35	
09	68,58	± 0,35	60,96	± 0,35	
10	76,20	± 0,35	68,58	± 0,35	
11	83,82	± 0,35	76,20	± 0,35	
12	91,44	± 0,35	83,82	± 0,35	
13	99,06	± 0,35	91,44	± 0,35	
14	106,68	± 0,35	99,06	± 0,35	
15	114,30	± 0,35	106,68	± 0,35	
16	121,92	± 0,35	114,30	± 0,35	

**Screwless Terminal Block**  
 Part No.: **A11R010**

DRW:	Jason	CHKD	Wilson	MATL:	Wilson	TOLERANCE	Mason	DATE	07.02.2014
APPD:	Schumi			FINISH	Jamy		Sheet No.		2 from 4

Customer:

# EDCON-COMPONENTS

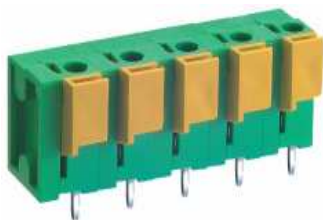

## Ordering Informations

Serie	No. of Pos.	Body Color	Approval	Approval Code	ROHS	Packing	EDCON Cust. No.	Customer Version		
-------	-------------	------------	----------	---------------	------	---------	-----------------	------------------	--	--

<b>A11R010</b>	<b>02</b>	<b>GN</b>	<b>N</b>	<b>N</b>	<b>R</b>	<b>B</b>				
----------------	-----------	-----------	----------	----------	----------	----------	--	--	--	--

Pitch	02= Number of Pos.	GY= Gray (Standard)	N= No Approval	N= NON Approval	R= ROHS Conform	B= Standard Package	xxxxxx= Customer Number	xxx= Customer Version ??(Printing)
-------	--------------------	---------------------	----------------	-----------------	-----------------	---------------------	-------------------------	------------------------------------

Standard 2~16 Pos.			1= Approval for Material	A= UL /UR Approval Please consult EDCON for available	N= NON ROHS Conform	I= Individual Package		
	GN= Green		2= Approval for Terminal Block					
				B= VDE Approval Please consult EDCON for available				
	OR= Orange							
	BK= Black			C= TÜV Approval Please consult EDCON for available				

**Screwless Terminal Block**

Part No.: **A11R010**

DRW:	Jason	CHKD	Wilson	MATL:	Wilson	TOLERANCE	Mason	DATE	07.02.2014
APPD:	Schumi			FINISH	Jamy		Sheet No.		3 from 4

Customer:

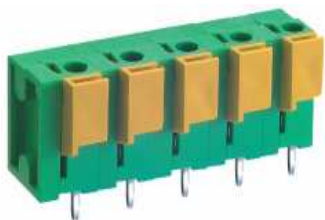

Soldering Profile Curve

Classification Reflow Profile (JEDEC J-STD-020C)



**Screwless Terminal Block**

Part No.: **A11R010**

Customer:

DRW:	Jason	CHKD	Wilson	MATL:	Wilson	TOLERANCE	Mason	DATE	07.02.2014
APPD:	Schumi			FINISH	Jamy		Sheet No.	4 from 4	



