

Data Sheet

Screwless Terminal Block

Pitch: 7,62 mm

Serie: A11R005

Customer Information for special Item

EDCON Customer : 0

Customer Version No. : 0

EDCON-COMPONENTS

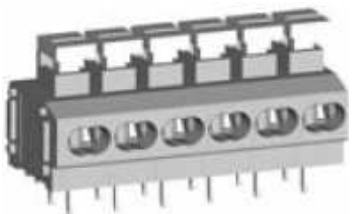

Technical Discription

Drawing (Dimension in mm)

Electrical

Standard	UL	IEC
Rated voltage	300V	250V
Rated current	5A	10A
Wire range	20-18 AWG	2 x 0.75mm ²
Withstanding voltage	AC2000V/1Min	

Mechanical

Wire strip length	9 ~ 10mm
Operating temperature	-40°C ~ +105°C

Dimensions

Pitch	7.62mm
Poles	1P - xxP

Material

Housing	PA66 (UL94V-0)
Pin header	Phosphor Bronze, Tin plated
Wire guard	Stainless steel

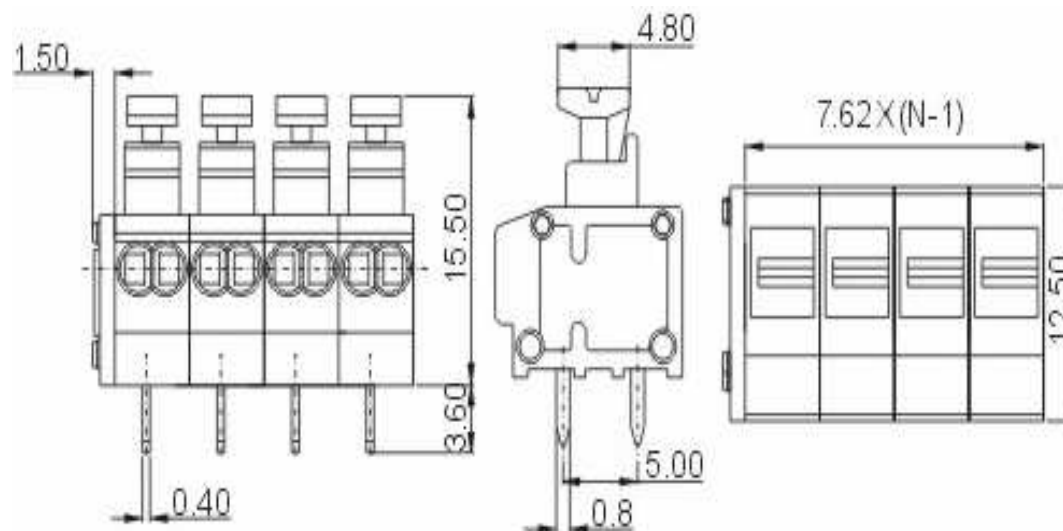

Screwless Terminal Block

Part No.: **A11R005**

Customer:

DRW:	Jason	CHKD	Wilson	MATL:	Wilson	TOLERANCE	Mason	DATE	07.02.2014
APPD:	Schumi			FINISH	Jamy		Sheet No.		1 from 4

EDCON-COMPONENTS

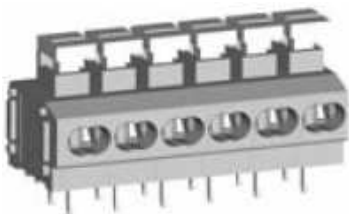

PCB Layout (Dimension in mm)

Dimensions (mm)

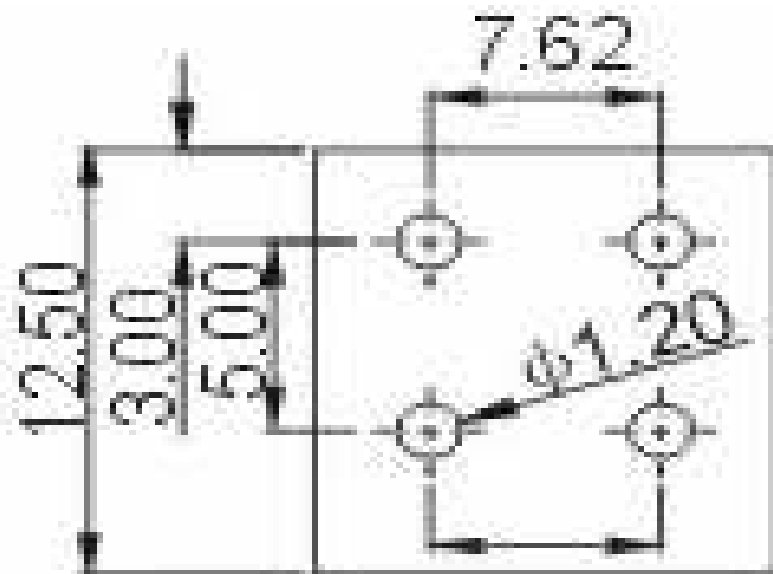

No. of Pos.	A	Tol. P	B	Tol. P
01	9,12	± 0,35	0,00	± 0,35
02	16,74	± 0,35	7,62	± 0,35
03	24,36	± 0,35	15,24	± 0,35
04	31,98	± 0,35	22,86	± 0,35
05	39,60	± 0,35	30,48	± 0,35
06	47,22	± 0,35	38,10	± 0,35
07	54,84	± 0,35	45,72	± 0,35
08	62,46	± 0,35	53,34	± 0,35
09	70,08	± 0,35	60,96	± 0,35
10	77,70	± 0,35	68,58	± 0,35
11	85,32	± 0,35	76,20	± 0,35
12	92,94	± 0,35	83,82	± 0,35

Screwless Terminal Block

Part No.: **A11R005**

DRW:	Jason	CHKD	Wilson	MATL:	Wilson	TOLERANCE	Mason	DATE	07.02.2014
APPD:	Schumi			FINISH	Jamy		Sheet No.	2 from 4	

Customer:

EDCON-COMPONENTS

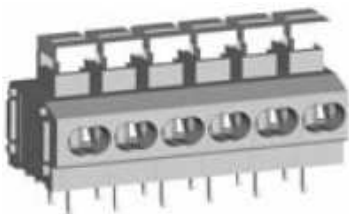

Ordering Informations

Serie	No. of Pos.	Body Color	Approval	Approval Code	ROHS	Packing	EDCON Cust. No.	Customer Version		
A11R005	02	GY	N	N	R	B				

Pitch
7,62

02= Number of Pos. Standard 1~12 Pos.	GY= Gray (Standard) GN= Green OR= Orange BK= Black	N= No Approval 1= Approval for Material 2= Approval for Terminal Block	N= NON Approval A= UL /UR Approval Please consult EDCON for available B= VDE Approval Please consult EDCON for available C= TÜV Approval Please consult EDCON for available	R= ROHS Conform N= NON ROHS Conform	B= Standard Package I= Individual Package	xxxxxx= Customer Number	xxx= Customer Version ??(Printing)
---	---	---	--	--	--	--------------------------------	---

Screwless Terminal Block	
Part No.:	A11R005
Customer:	

DRW:	Jason	CHKD	Wilson	MATL:	Wilson	TOLERANCE	Mason	DATE	07.02.2014
APPD:	Schumi			FINISH	Jamy			Sheet No.	3 from 4

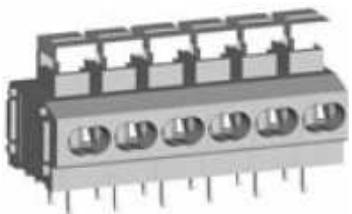

Soldering Profile Curve

Classification Reflow Profile (JEDEC J-STD-020C)



Screwless Terminal Block

Part No.: **A11R005**

Customer:

DRW:	Jason	CHKD	Wilson	MATL:	Wilson	TOLERANCE	Mason	DATE	07.02.2014
APPD:	Schumi			FINISH	Jamy		Sheet No.	4 from 4	

