

Data Sheet

Screwless Terminal Block Pitch 7,50mm

Pitch: 7,50 mm

Serie: A11Q069

Customer Information for special Item

EDCON Customer : xxxxxx

Customer Version No. : xx

EDCON-COMPONENTS



Technical Description

Electrical:

Rated voltage:
Rated current:
Withstanding Voltage: AC/1min:
Operating Temperature:

UL	IEC	VDE
300V	750V	
15A	17A	
2500V	2500V	

-40°C ~ +105°C

Mechanical:

Strip length: mm
Wire range: Solid wire: AWG
Wire range: Stranded wire: AWG

5-6mm	5-6mm	
28~12	2,5mm ²	

Material:

Housing Terminal Body: PA66 UL94V-0
Housing Left-side: PA66 UL94V-0
Housing Right side: PA66 UL94V-0
Lever:
Terminal: Copper Matte Tin plated over Nickel
Spring Clamp: Stainless steel

Drawing (Dimension in mm)

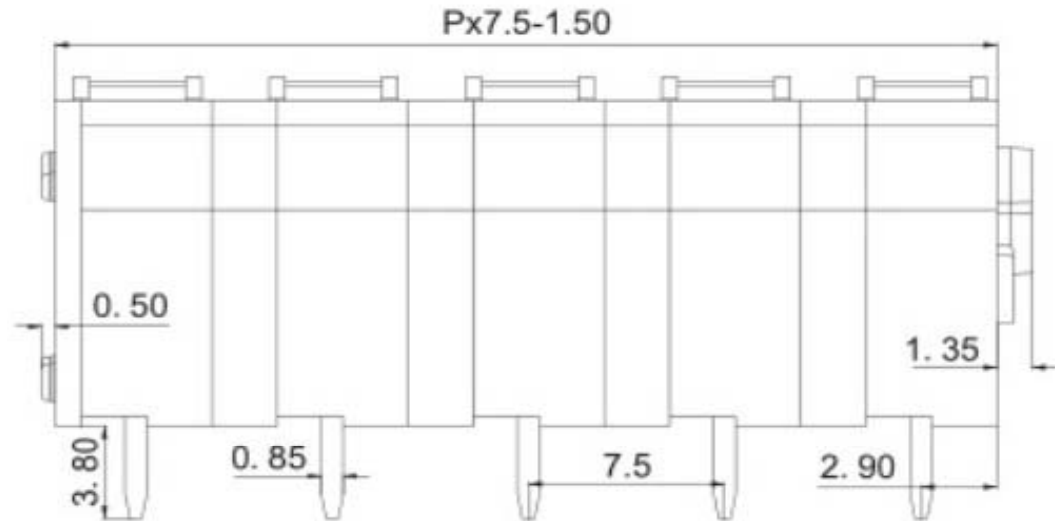

Tolerances unless otherwise specified (mm)

X	X.X	X.XX	X.XXX	Angle
±	±	±	±	±3°

**Screwless Terminal Block Pitch
7,50mm**

Part No.: **A11Q069**

Customer:

DRW:	Jason	CHKD	Wilson	MATL:	Wilson	TOLERANCE	Mason	DATE	08.01.2021
APPD:	Schumi			FINISH	Jamy			Sheet No.	1 from 4

EDCON-COMPONENTS



PCB Layout Dimension (mm)
TOP-VIEW

Dimensions (mm)

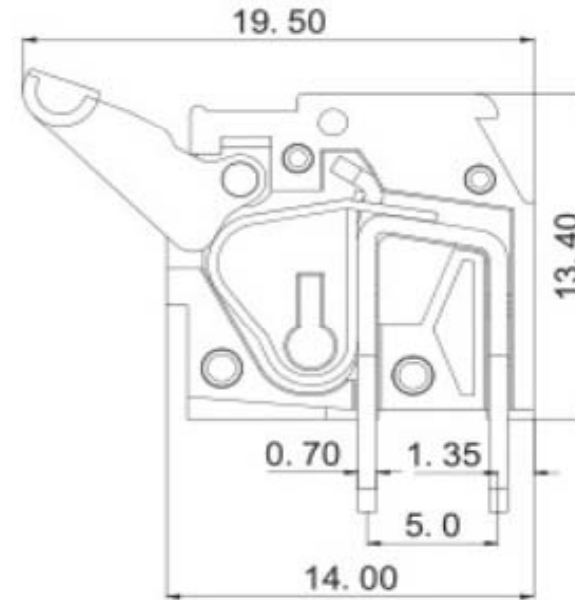
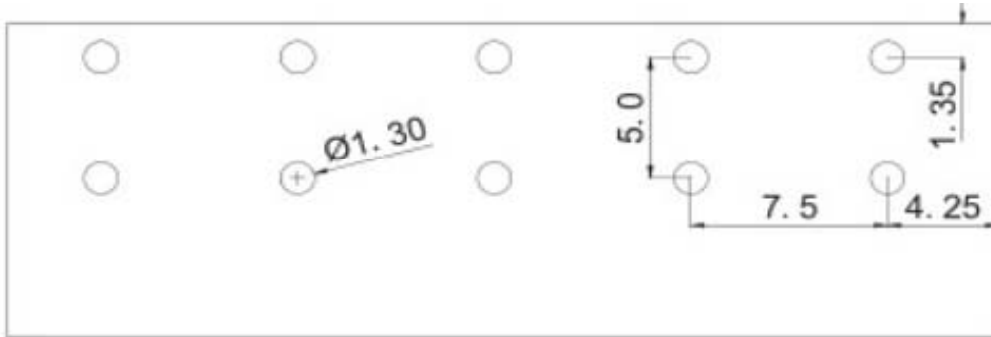

Frontside

**Screwless Terminal Block Pitch
7,50mm**

Part No.: **A11Q069**

Customer:

DRW:	Jason	CHKD	Wilson	MATL:	Wilson	TOLERANCE	Mason	DATE	08.01.2021
APPD:	Schumi			FINISH	Jamy		Sheet No.	2 from 4	

EDCON-COMPONENTS



Ordering Informations

Serie	No. of Pos.	Body Color	Srew Type	Approval Code	ROHS	Packing	EDCON Cust. No.	Customer Version		
A11Q069	02	GY	C	N	R	B	xxxxxx	xx		

Pitch	02= Number of Pos.	GY= Gray (Standard)	C= Screwless Type	N= NON Approval	R= ROHS Conform	B= Standard Package Box/ Polybag	xxxxxx= Customer Number	xx= Customer Version (Printing) ??
7,50	Standard 1 ~ 16Pos.			1= UL-Approval for Body Material	N= NON ROHS Conform	I= Individual Package		
				A= UL /UR Approval Please consult EDCON for available				
				B= VDE Approval Please consult EDCON for available				
				C= TÜV Approval Please consult EDCON for available				

Screwless Terminal Block Pitch	
7,50mm	
Part No.:	A11Q069
Customer:	

DRW:	Jason	CHKD	Wilson	MATL:	Wilson	TOLERANCE	Mason	DATE	08.01.2021
APPD:	Schumi			FINISH	Jamy		Sheet No.		3 from 4



Soldering Profile Curve

Classification Reflow Profile (JEDEC J-STD-020C)

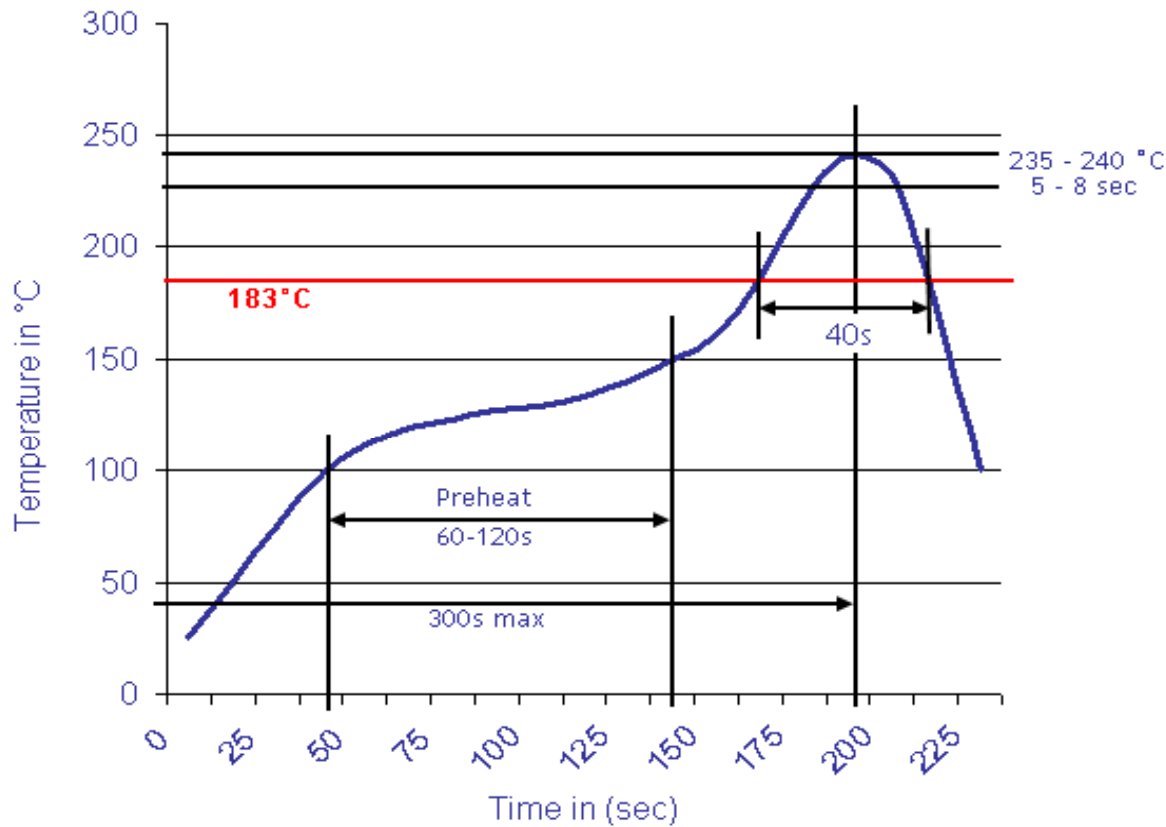

Screwless Terminal Block Pitch 7,50mm	
Part No.:	A11Q069
Customer:	

DRW:	Jason	CHKD	Wilson	MATL:	Wilson	TOLERANCE	Mason	DATE	08.01.2021
APPD:	Schumi			FINISH	Jamy		Sheet No.	4 from 4	