

Data Sheet

Screwless Terminal Block Pitch 7,50mm

Pitch: 7,50 mm

Serie: A11Q055

Customer Information for special Item

EDCON Customer : xxxxxx

Customer Version No. : xx

EDCON-COMPONENTS



Technical Discription

Electrical:

Rated voltage:

Rated current:

Withstanding Voltage: AC/1min:

Operating Temperature:

Mechanical:

Strip length: mm

Wire range: Solid wire: AWG

Wire range: Stranded wire:AWG

Material:

Housing Terminal Body:

Housing Left-side:

Housing Right side:

Lever:

Terminal:

Spring Clamp:

UL	IEC	VDE
300V	450V	
30A	41A	
3000V	3000V	

-40°C ~ +105°C

15~16mm	15~16mm	
24~10	6mm ²	

PA66 UL94V-0

PA66 UL94V-0

PA66 UL94V-0

Copper Matte Tin plated over Nickel

Stainless steel

Drawing (Dimension in mm)

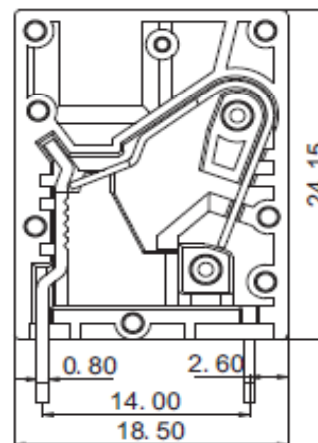
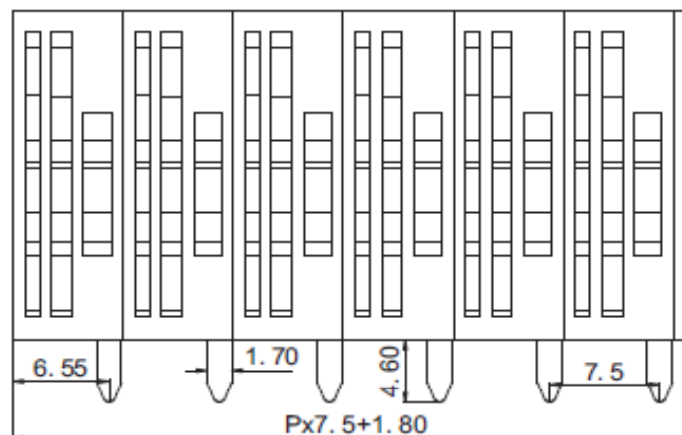

Item No.		
1		
2		
3		
4		
5		
6		
7		
8		
9		

Tolerances unless otherwise specified (mm)

X	X.X	X.XX	X.XXX	Angle					
±	±	±	±	±3°					
DRW:	Jason	CHKD	Wilson	MATL:	Wilson	TOLERANCE	Mason	DATE	30.11.2020
APPD:	Schumi			FINISH	Jamy			Sheet No.	1 from 4

Screwless Terminal Block Pitch 7,50mm

Part No.: **A11Q055**

Customer:

EDCON-COMPONENTS



PCB Layout Dimension (mm)
TOP-VIEW

Dimensions (mm)

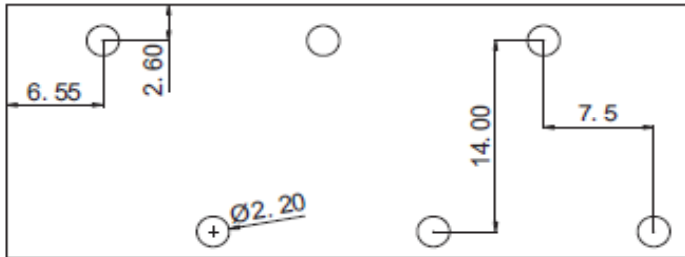

Frontside

**Screwless Terminal Block Pitch
7,50mm**

Part No.: **A11Q055**

DRW:	Jason	CHKD	Wilson	MATL:	Wilson	TOLERANCE	Mason	DATE	30.11.2020	Customer:
APPD:	Schumi			FINISH	Jamy		Sheet No.	2 from 4		

www.edcon-components.com

email: info@edcon-components.com

EDCON-COMPONENTS



Ordering Informations

Serie	No. of Pos.	Body Color	Srew Type	Approval Code	ROHS	Packing	EDCON Cust. No.	Customer Version		
A11Q055	02	PG	C	N	R	B	xxxxxx	xx		

Pitch 7,50

02 = Number of Pos. Standard 1 ~ 16Pos.		C = Screwless Type	N = NON Approval 1 = UL-Approval for Body Material A = UL /UR Approval Please consult EDCON for available B = VDE Approval Please consult EDCON for available C = TÜV Approval Please consult EDCON for available	R = ROHS Conform N = NON ROHS Conform	B = Standard Package Box/ Polybag I = Individual Package	xxxxxx = Customer Number	xx = Customer Version (Printing) ??
		PG = Phoenix Green					

Screwless Terminal Block Pitch 7,50mm
Part No.: A11Q055
Customer:

DRW:	Jason	CHKD	Wilson	MATL:	Wilson	TOLERANCE	Mason	DATE	30.11.2020
APPD:	Schumi			FINISH	Jamy		Sheet No.		3 from 4



Soldering Profile Curve

Classification Reflow Profile (JEDEC J-STD-020C)

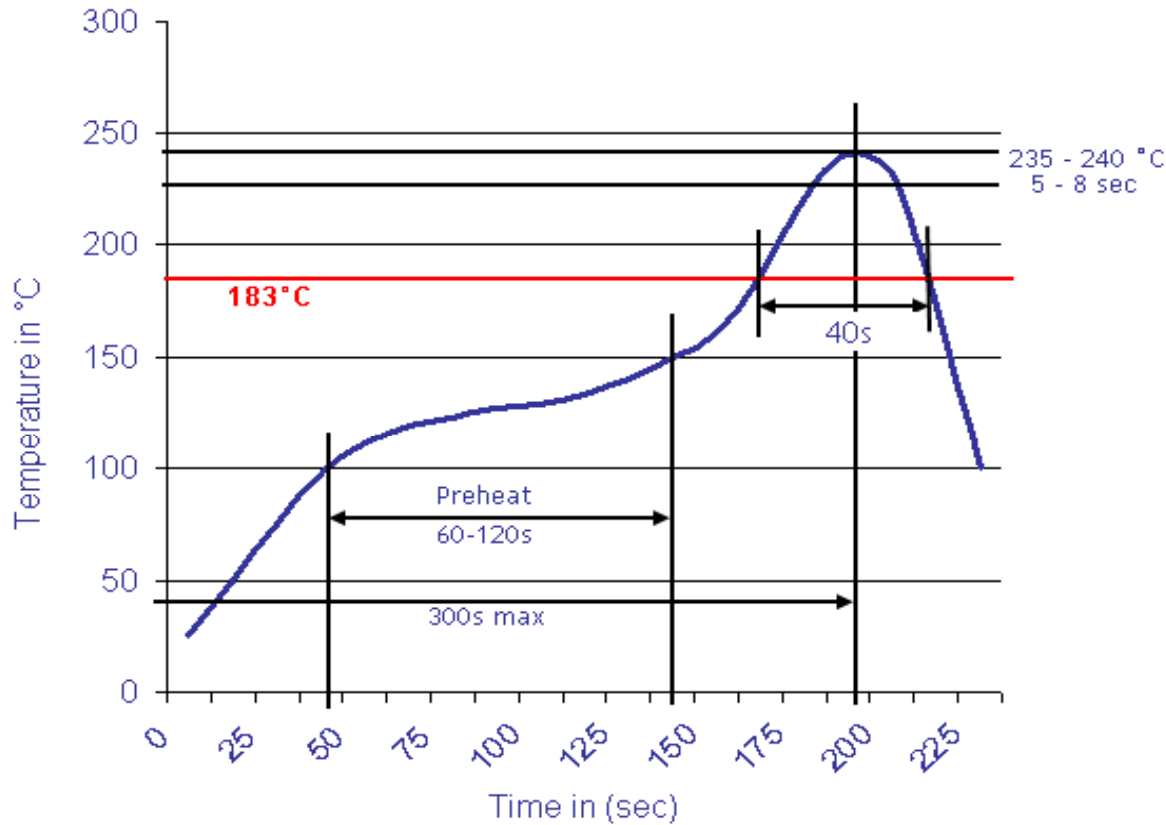

Screwless Terminal Block Pitch
7,50mm

Part No.: **A11Q055**

Customer:

DRW:	Jason	CHKD	Wilson	MATL:	Wilson	TOLERANCE	Mason	DATE	30.11.2020
APPD:	Schumi			FINISH	Jamy		Sheet No.	4 from 4	