

Data Sheet

Screwless Terminal Block

Pitch: 7,50 mm

Serie: A11Q024

Customer Information for special Item

EDCON Customer : 0

Customer Version No. : 0

EDCON-COMPONENTS



Technical Discription

Drawing (Dimension in mm)

Electrical

Standard UL, VDE
 Rated voltage 250V
 Rated current 2A
 Wire range 14-22 AWG

Mechanical

Operating temperature -40°C ~ +105°C

Dimensions

Pitch 7.50mm
 Poles 2P - 24P

Material

Housing Nylon PA66 (UL94V-0)
 Pin header Brass, Tin plated
 Wire guard Stainless steel

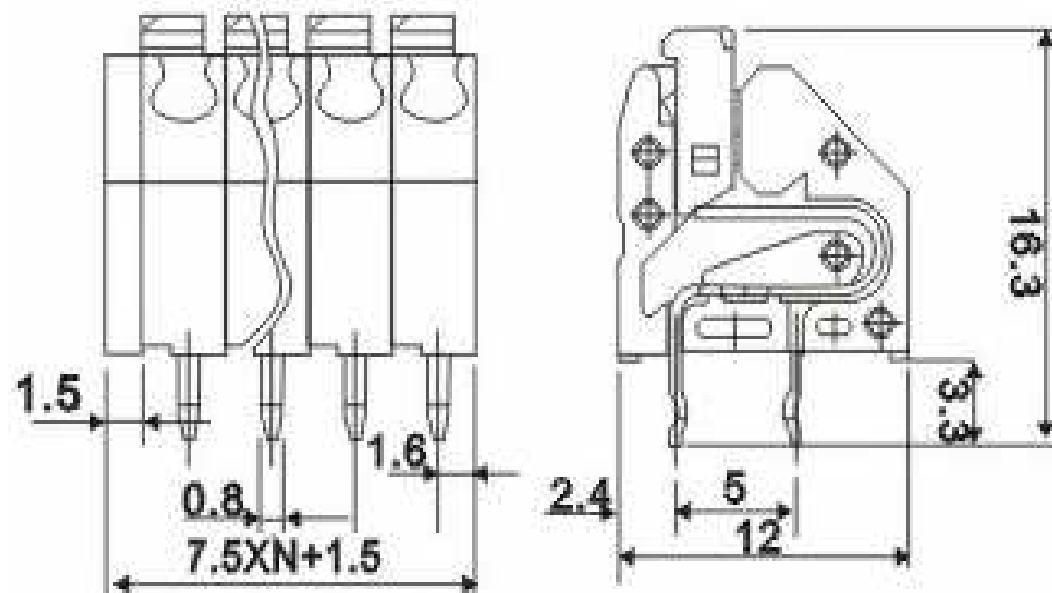

Screwless Terminal Block

Part No.: **A11Q024**

Customer:

DRW:	Jason	CHKD	Wilson	MATL:	Wilson	TOLERANCE	Mason	DATE	06.02.2014
APPD:	Schumi			FINISH	Jamy		Sheet No.	1 from 4	

EDCON-COMPONENTS



PCB Layout (Dimension in mm)

Dimensions (mm)

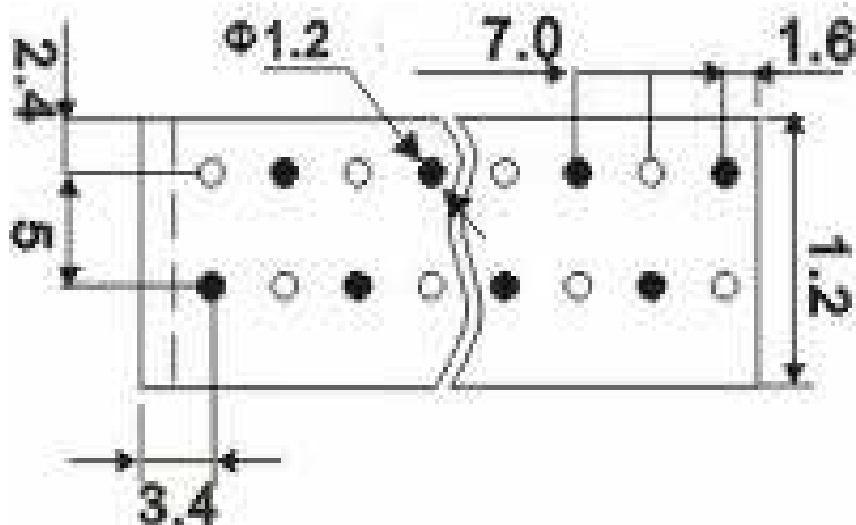

No. of Pos.	A	Tol. P	B	Tol. P
02	16,50	± 0,35	7,50	± 0,35
03	24,00	± 0,35	15,00	± 0,35
04	31,50	± 0,35	22,50	± 0,35
05	39,00	± 0,35	30,00	± 0,35
06	46,50	± 0,35	37,50	± 0,35
07	54,00	± 0,35	45,00	± 0,35
08	61,50	± 0,35	52,50	± 0,35
09	69,00	± 0,35	60,00	± 0,35
10	76,50	± 0,35	67,50	± 0,35
11	84,00	± 0,35	75,00	± 0,35
12	91,50	± 0,35	82,50	± 0,35
13	99,00	± 0,35	90,00	± 0,35
14	106,50	± 0,35	97,50	± 0,35
15	114,00	± 0,35	105,00	± 0,35
16	121,50	± 0,35	112,50	± 0,35
17	129,00	± 0,35	120,00	± 0,35
18	136,50	± 0,35	127,50	± 0,35
19	144,00	± 0,35	135,00	± 0,35
20	151,50	± 0,35	142,50	± 0,35
21	159,00	± 0,35	150,00	± 0,35
22	166,50	± 0,35	157,50	± 0,35
23	174,00	± 0,35	165,00	± 0,35
24	181,50	± 0,35	172,50	± 0,35

Screwless Terminal Block

Part No.: **A11Q024**

DRW:	Jason	CHKD	Wilson	MATL:	Wilson	TOLERANCE	Mason	DATE	06.02.2014
APPD:	Schumi			FINISH	Jamy		Sheet No.	2 from 4	

Customer:

EDCON-COMPONENTS



Ordering Informations

Serie	No. of Pos.	Body Color	Approval	Approval Code	ROHS	Packing	EDCON Cust. No.	Customer Version		
-------	-------------	------------	----------	---------------	------	---------	-----------------	------------------	--	--

A11Q024	02	GY	N	N	R	B				
----------------	-----------	-----------	----------	----------	----------	----------	--	--	--	--

Pitch 7,50	02 = Number of Pos. Standard 2~24 Pos.	GY = Gray (Standard) GN = Green OR = Orange BK = Black	N = No Approval 1 = Approval for Material 2 = Approval for Terminal Block	N = NON Approval A = UL /UR Approval Please consult EDCON for available B = VDE Approval Please consult EDCON for available C = TÜV Approval Please consult EDCON for available	R = ROHS Conform N = NON ROHS Conform	B = Standard Package I = Individual Package	xxxxxx = Customer Number	xxx = Customer Version ??(Printing)		
---------------	--	---	--	--	--	--	---------------------------------	--	--	--

Screwless Terminal Block

Part No.: **A11Q024**

DRW:	Jason	CHKD	Wilson	MATL:	Wilson	TOLERANCE	Mason	DATE	06.02.2014
APPD:	Schumi			FINISH	Jamy		Sheet No.		3 from 4

Customer:



Soldering Profile Curve

Classification Reflow Profile (JEDEC J-STD-020C)

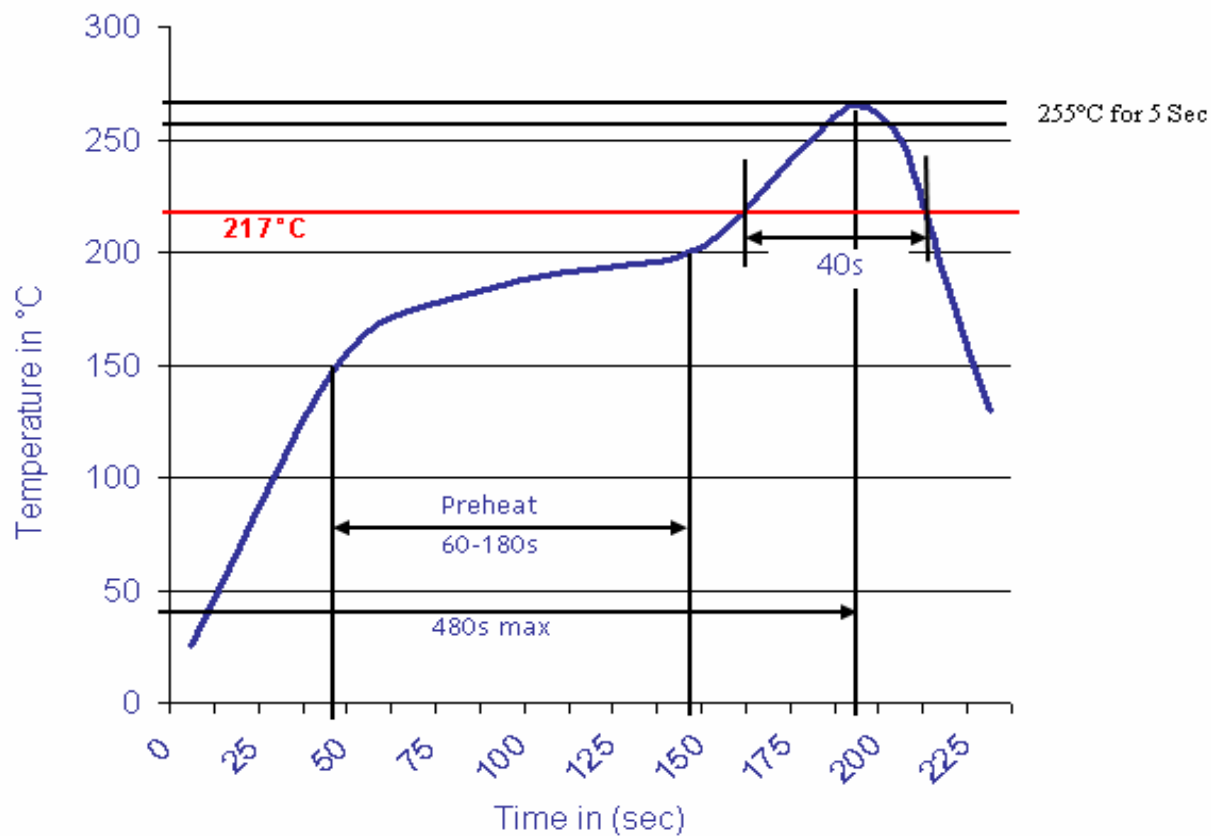

Screwless Terminal Block

Part No.: **A11Q024**

Customer:

DRW:	Jason	CHKD	Wilson	MATL:	Wilson	TOLERANCE	Mason	DATE	06.02.2014
APPD:	Schumi			FINISH	Jamy		Sheet No.	4 from 4	

