

# Data Sheet

## Screwless Terminal Block

**Pitch: 7,50 mm**

**Serie: A11Q006**

### Customer Information for special Item

**EDCON Customer : 0**

**Customer Version No. : 0**

# EDCON-COMPONENTS

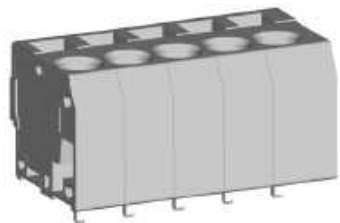

## Technical Discription

## Drawing (Dimension in mm)

### Electrical

Standard	cULus
Rated voltage	250V
Rated current	8A
Withstanding voltage	1.5KV
Solid / Stranded wire	28-12 AWG

### Mechanical

Wire strip length	6 ~ 7mm
Ambient temperature	-40°C ~ +115°C
Soldering temperature	250°C ±10°C/5 sec

### Dimensions

Pitch	7.50mm
Poles	2P - 12P

### Material

Housing	Thermoplastic (UL94V-0)
Pin header	Brass, Tin plated
Wire guard	Stainless steel

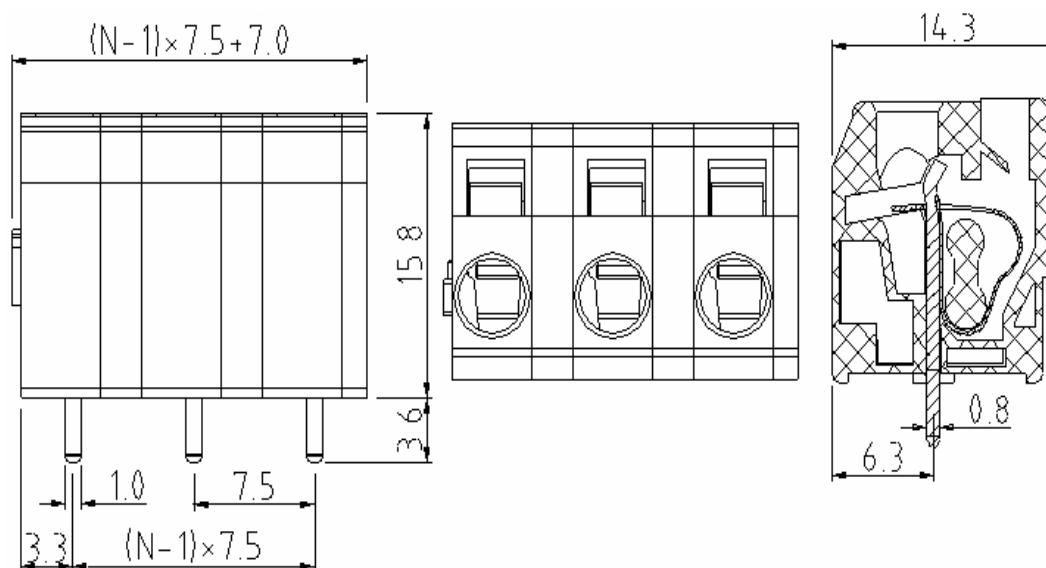

### Screwless Terminal Block

Part No.: **A11Q006**

Customer:

DRW:	Jason	CHKD	Wilson	MATL:	Wilson	TOLERANCE	Mason	DATE	04.02.2014
APPD:	Schumi			FINISH	Jamy		Sheet No.	1 from 4	

# EDCON-COMPONENTS

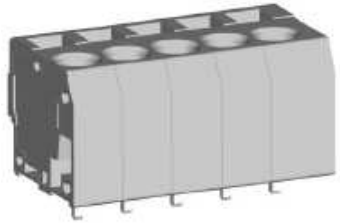

PCB Layout (Dimension in mm)

Dimensions (mm)

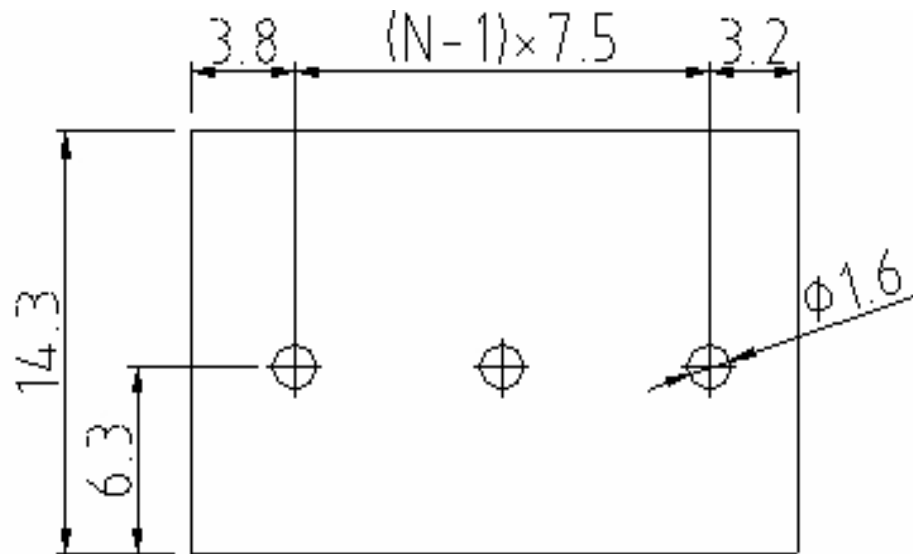

No. of Pos.	A	Tol. P	B	Tol. P
02	22,00	± 0,35	7,50	± 0,35
03	29,50	± 0,35	15,00	± 0,35
04	37,00	± 0,35	22,50	± 0,35
05	44,50	± 0,35	30,00	± 0,35
06	52,00	± 0,35	37,50	± 0,35
07	59,50	± 0,35	45,00	± 0,35
08	67,00	± 0,35	52,50	± 0,35
09	74,50	± 0,35	60,00	± 0,35
10	82,00	± 0,35	67,50	± 0,35
11	89,50	± 0,35	75,00	± 0,35
12	97,00	± 0,35	82,50	± 0,35

**Screwless Terminal Block**  
 Part No.: **A11Q006**

DRW:	Jason	CHKD	Wilson	MATL:	Wilson	TOLERANCE	Mason	DATE	04.02.2014
APPD:	Schumi			FINISH	Jamy		Sheet No.	2 from 4	Customer:

# EDCON-COMPONENTS

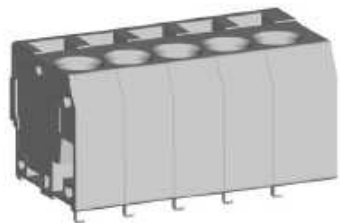

## Ordering Informations

Serie	No. of Pos.	Body Color	Approval	Approval Code	ROHS	Packing	EDCON Cust. No.	Customer Version		
<b>A11Q006</b>	<b>02</b>	<b>GY</b>	<b>N</b>	<b>N</b>	<b>R</b>	<b>B</b>				

Pitch  
7,50

<b>02=</b> Number of Pos. Standard 2~12 Pos.	<b>GY=</b> Gray (Standard)  <b>GN=</b> Green  <b>OR=</b> Orange  <b>BK=</b> Black	<b>N=</b> No Approval  <b>1=</b> Approval for Material  <b>2=</b> Approval for Terminal Block	<b>N=</b> NON Approval  <b>A=</b> UL /UR Approval Please consult EDCON for available  <b>B=</b> VDE Approval Please consult EDCON for available  <b>C=</b> TÜV Approval Please consult EDCON for available	<b>R=</b> ROHS Conform  <b>N=</b> NON ROHS Conform	<b>B=</b> Standard Package  <b>I=</b> Individual Package	<b>xxxxxx=</b> Customer Number	<b>xxx=</b> Customer Version ??(Printing)
---	---	---	--	--	--	--------------------------------	---

**Screwless Terminal Block**

Part No.: **A11Q006**

DRW:	Jason	CHKD	Wilson	MATL:	Wilson	TOLERANCE	Mason	DATE	04.02.2014
APPD:	Schumi			FINISH	Jamy		Sheet No.		3 from 4

Customer:

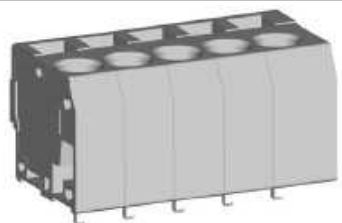

Soldering Profile Curve

Classification Reflow Profile (JEDEC J-STD-020C)

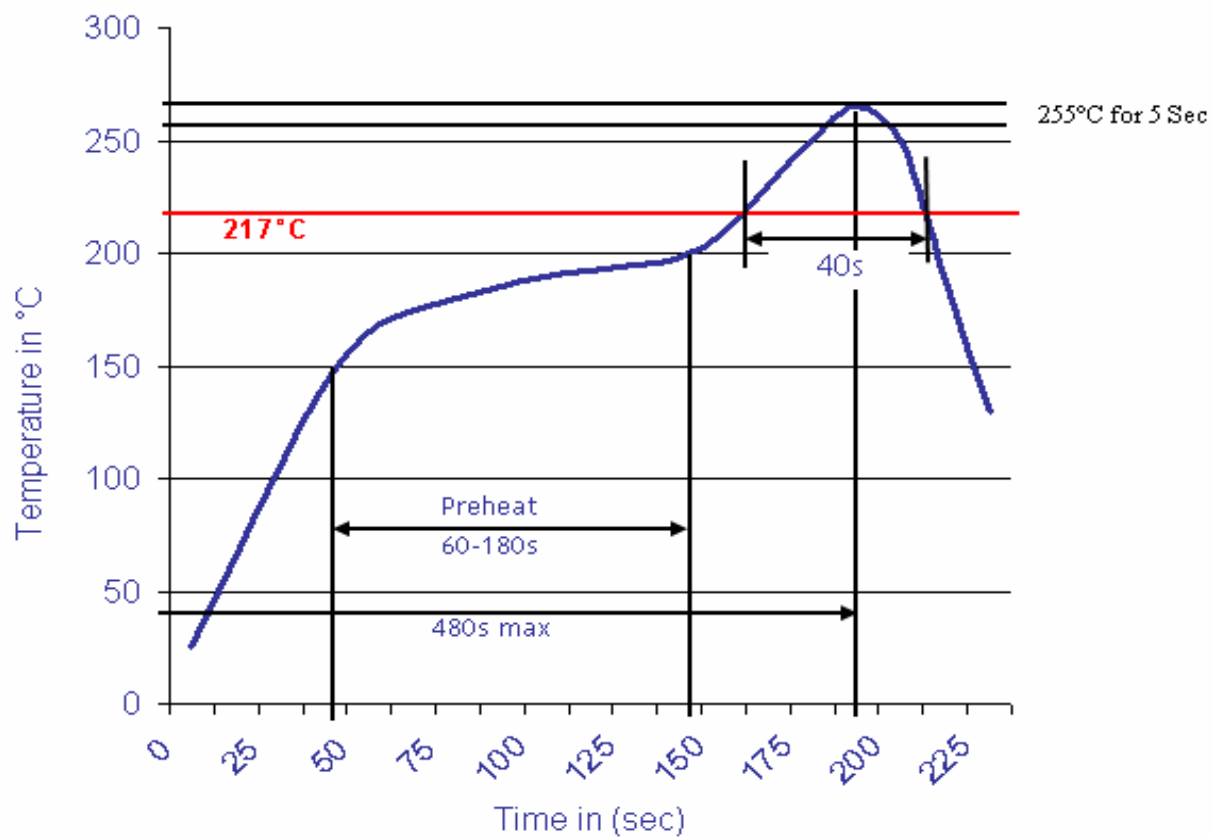

**Screwless Terminal Block**

Part No.: **A11Q006**

Customer:

DRW:	Jason	CHKD	Wilson	MATL:	Wilson	TOLERANCE	Mason	DATE	04.02.2014
APPD:	Schumi			FINISH	Jamy		Sheet No.	4 from 4	



