

Data Sheet

Screwless Terminal Block

Pitch: 7,00 mm

Serie: A11P001

Customer Information for special Item

EDCON Customer : 0

Customer Version No. : 0

EDCON-COMPONENTS



Technical Discription

Drawing (Dimension in mm)

Electrical

Standard
 Rated voltage
 Rated current
 Solid / Stranded wire
 Withstanding voltage
 Wire range

cULus	VDE
300V	250V
6A	6A
20-16 AWG	20-16 AWG
1.6KV	2KV
0.5 ~ 0.75mm ²	

Mechanical

Wire strip length
 Ambient temperature
 Soldering temperature

6 ~ 7mm
 -40°C ~ +115°C
 250°C ±10°C/5 sec

Dimensions

Pitch
 Poles

7.00mm
 2P - 12P

Material

Housing
 Pin header
 Wire guard

Thermoplastic (UL94V-0)
 Brass, Tin plated
 Stainless steel

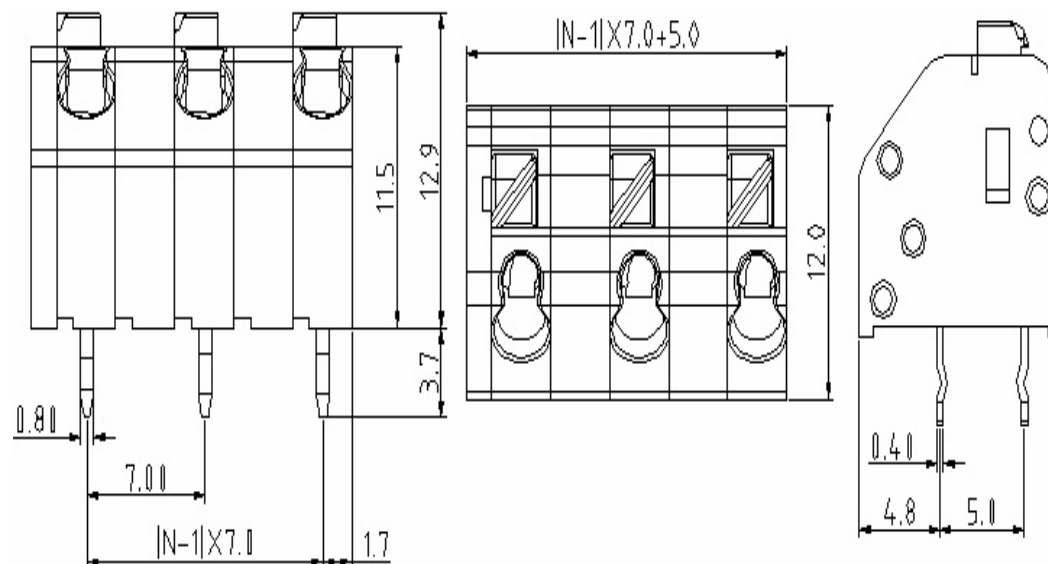

Screwless Terminal Block

Part No.: **A11P001**

Customer:

DRW:	Jason	CHKD	Wilson	MATL:	Wilson	TOLERANCE	Mason	DATE	03.02.2014
APPD:	Schumi			FINISH	Jamy		Sheet No.	1 from 4	

EDCON-COMPONENTS



Ordering Informations

Serie	No. of Pos.	Body Color	Approval	Approval Code	ROHS	Packing	EDCON Cust. No.	Customer Version		
-------	-------------	------------	----------	---------------	------	---------	-----------------	------------------	--	--

A11P001	02	GY	N	N	R	B				
----------------	-----------	-----------	----------	----------	----------	----------	--	--	--	--

Pitch 7,00	02 = Number of Pos. Standard 2~12 Pos.	GY = Gray (Standard) GN = Green OR = Orange BK = Black	N = No Approval 1 = Approval for Material 2 = Approval for Terminal Block	N = NON Approval A = UL /UR Approval Please consult EDCON for available B = VDE Approval Please consult EDCON for available C = TÜV Approval Please consult EDCON for available	R = ROHS Conform N = NON ROHS Conform	B = Standard Package I = Individual Package	xxxxxx = Customer Number	xxx = Customer Version ??(Printing)		
---------------	--	---	--	--	--	--	---------------------------------	--	--	--

Screwless Terminal Block

Part No.: **A11P001**

Customer:

DRW:	Jason	CHKD	Wilson	MATL:	Wilson	TOLERANCE	Mason	DATE	03.02.2014
APPD:	Schumi			FINISH	Jamy		Sheet No.		3 from 4



Soldering Profile Curve

Classification Reflow Profile (JEDEC J-STD-020C)



Screwless Terminal Block

Part No.: **A11P001**

Customer:

DRW:	Jason	CHKD	Wilson	MATL:	Wilson	TOLERANCE	Mason	DATE	03.02.2014
APPD:	Schumi			FINISH	Jamy		Sheet No.	4 from 4	

