

Data Sheet

Screwless Terminal Block

Pitch: 5,08 mm

Serie: A11M014

Customer Information for special Item

EDCON Customer : 0

Customer Version No. : 0

EDCON-COMPONENTS



Technical Discription

Drawing (Dimension in mm)

Electrical

Standard
 Rated voltage
 Rated current
 Wire range
 Withstanding voltage

UL	IEC
300V	250V, 450V
15A	16A
28-12 AWG	2.5mm ²
AC2000V/1Min	

Mechanical

Wire strip length
 Operating temperature

5 ~ 6mm
 -40°C ~ +105°C

Dimensions

Pitch
 Poles

5.08mm
 1P - xxP

Material

Housing
 Pin header
 Wire guard

PA66 (UL94V-0)
 Phosphor Bronze, Tin plated
 Stainless steel

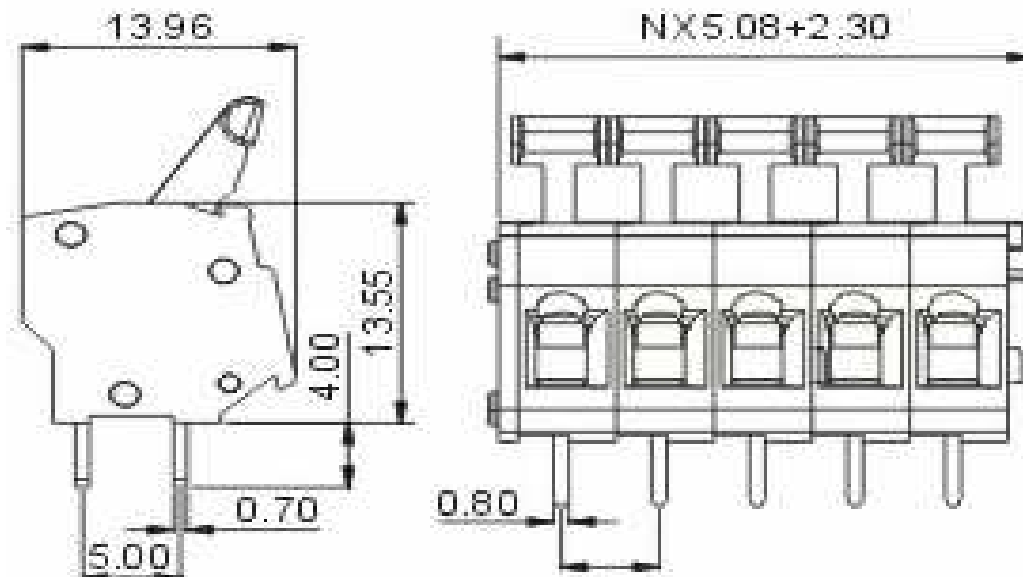

Screwless Terminal Block

Part No.: **A11M014**

Customer:

DRW:	Jason	CHKD	Wilson	MATL:	Wilson	TOLERANCE	Mason	DATE	03.02.2014
APPD:	Schumi			FINISH	Jamy		Sheet No.	1 from 4	

EDCON-COMPONENTS



PCB Layout (Dimension in mm)

Dimensions (mm)

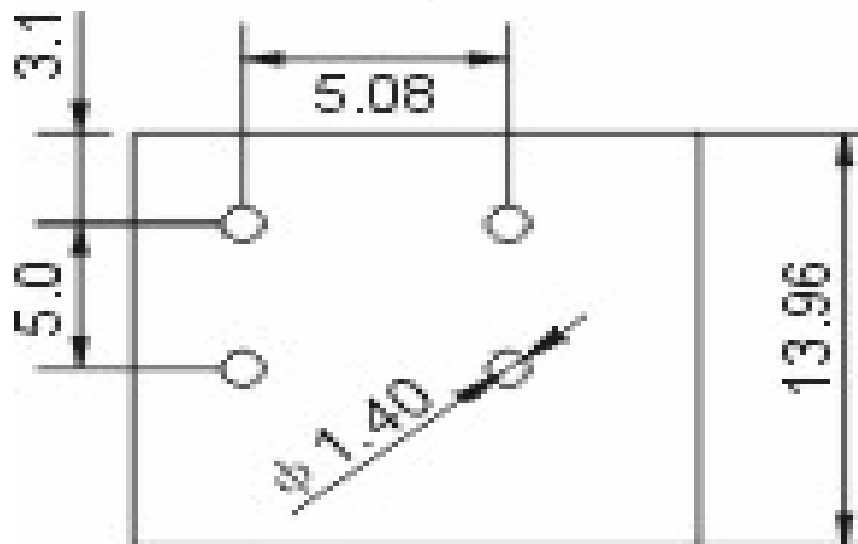

No. of Pos.	A	Tol. P	B	Tol. P
02	12,46	± 0,35	5,08	± 0,35
03	17,54	± 0,35	10,16	± 0,35
04	22,62	± 0,35	15,24	± 0,35
05	27,70	± 0,35	20,32	± 0,35
06	32,78	± 0,35	25,40	± 0,35
07	37,86	± 0,35	30,48	± 0,35
08	42,94	± 0,35	35,56	± 0,35
09	48,02	± 0,35	40,64	± 0,35
10	53,10	± 0,35	45,72	± 0,35
11	58,18	± 0,35	50,80	± 0,35
12	63,26	± 0,35	55,88	± 0,35
13	68,34	± 0,35	60,96	± 0,35
14	73,42	± 0,35	66,04	± 0,35
15	78,50	± 0,35	71,12	± 0,35
16	83,58	± 0,35	76,20	± 0,35
17	88,66	± 0,35	81,28	± 0,35
18	93,74	± 0,35	86,36	± 0,35
19	98,82	± 0,35	91,44	± 0,35
20	103,90	± 0,35	96,52	± 0,35
21	108,98	± 0,35	101,60	± 0,35
22	114,06	± 0,35	106,68	± 0,35
23	119,14	± 0,35	111,76	± 0,35
24	124,22	± 0,35	116,84	± 0,35

Screwless Terminal Block

Part No.: **A11M014**

Customer:

DRW:	Jason	CHKD	Wilson	MATL:	Wilson	TOLERANCE	Mason	DATE	03.02.2014
APPD:	Schumi			FINISH	Jamy		Sheet No.		2 from 4

EDCON-COMPONENTS



Ordering Informations

Serie	No. of Pos.	Body Color	Approval	Approval Code	ROHS	Packing	EDCON Cust. No.	Customer Version		
A11M014	02	GY	N	N	R	B				

Pitch
5,08

02= Number of Pos. Standard 2~24 Pos.	GY= Gray (Standard) GN= Green OR= Orange BK= Black	N= No Approval 1= Approval for Material 2= Approval for Terminal Block	N= NON Approval A= UL /UR Approval Please consult EDCON for available B= VDE Approval Please consult EDCON for available C= TÜV Approval Please consult EDCON for available	R= ROHS Conform N= NON ROHS Conform	B= Standard Package I= Individual Package	xxxxxx= Customer Number	xxx= Customer Version ??(Printing)
---	---	---	--	--	--	--------------------------------	---

Screwless Terminal Block	
Part No.:	A11M014
Customer:	

DRW:	Jason	CHKD	Wilson	MATL:	Wilson	TOLERANCE	Mason	DATE	03.02.2014
APPD:	Schumi			FINISH	Jamy			Sheet No.	3 from 4



Soldering Profile Curve

Classification Reflow Profile (JEDEC J-STD-020C)

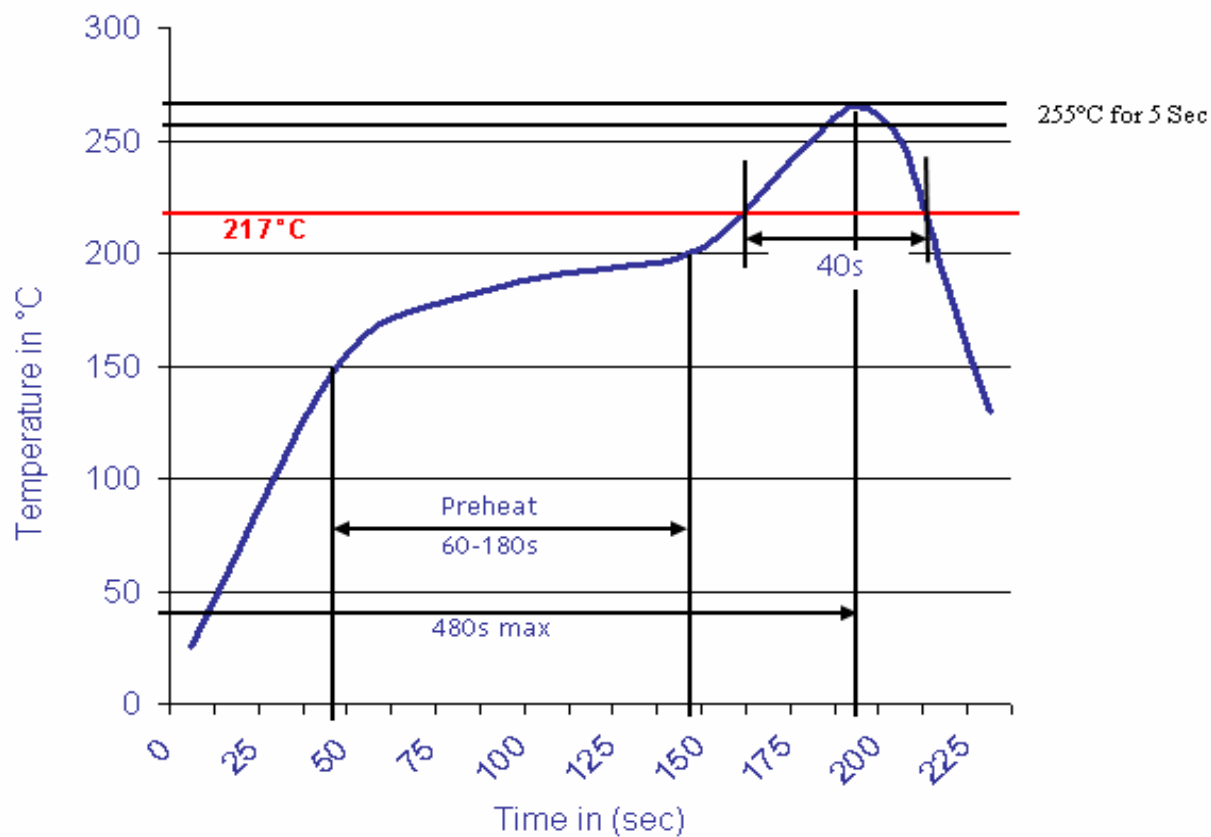

Screwless Terminal Block

Part No.: **A11M014**

Customer:

DRW:	Jason	CHKD	Wilson	MATL:	Wilson	TOLERANCE	Mason	DATE	03.02.2014
APPD:	Schumi			FINISH	Jamy		Sheet No.	4 from 4	

