

Data Sheet

Screwless Terminal Block

Pitch: 5,08 mm

Serie: A11M008

Customer Information for special Item

EDCON Customer : 0

Customer Version No. : 0

EDCON-COMPONENTS

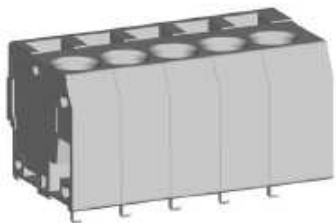

Technical Discription

Drawing (Dimension in mm)

Electrical

Standard	cULus
Rated voltage	250V
Rated current	8A
Withstanding voltage	1.5KV
Solid / Stranded wire	28-12 AWG

Mechanical

Wire strip length	6 ~ 7mm
Ambient temperature	-40°C ~ +115°C
Soldering temperature	250°C ±10°C/5 sec

Dimensions

Pitch	5.08mm
Poles	2P - 24P

Material

Housing	Thermoplastic (UL94V-0)
Pin header	Brass, Tin plated
Wire guard	Stainless steel

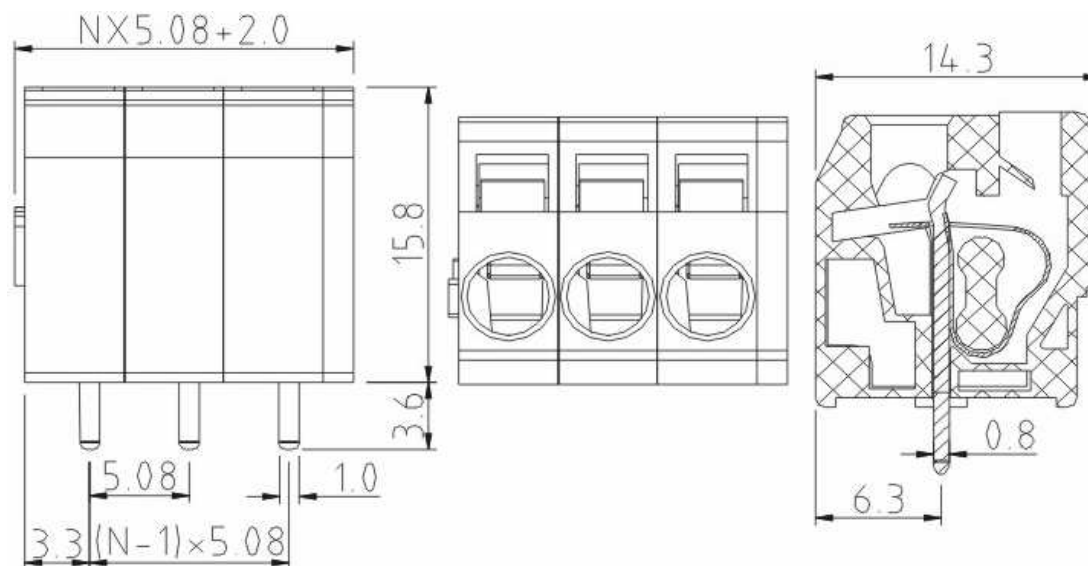

Screwless Terminal Block

Part No.: **A11M008**

Customer:

DRW:	Jason	CHKD	Wilson	MATL:	Wilson	TOLERANCE	Mason	DATE	03.02.2014
APPD:	Schumi			FINISH	Jamy		Sheet No.		1 from 4

EDCON-COMPONENTS

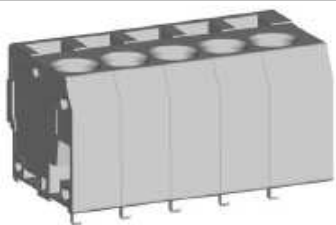

PCB Layout (Dimension in mm)

Dimensions (mm)

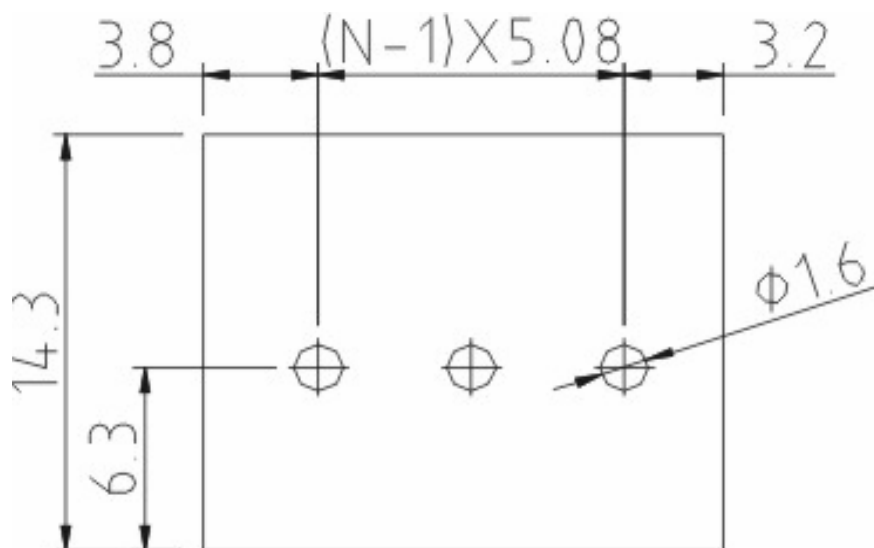

No. of Pos.	A	Tol. P	B	Tol. P
02	12,16	± 0,35	5,08	± 0,35
03	17,24	± 0,35	10,16	± 0,35
04	22,32	± 0,35	15,24	± 0,35
05	27,40	± 0,35	20,32	± 0,35
06	32,48	± 0,35	25,40	± 0,35
07	37,56	± 0,35	30,48	± 0,35
08	42,64	± 0,35	35,56	± 0,35
09	47,72	± 0,35	40,64	± 0,35
10	52,80	± 0,35	45,72	± 0,35
11	57,88	± 0,35	50,80	± 0,35
12	62,96	± 0,35	55,88	± 0,35
13	68,04	± 0,35	60,96	± 0,35
14	73,12	± 0,35	66,04	± 0,35
15	78,20	± 0,35	71,12	± 0,35
16	83,28	± 0,35	76,20	± 0,35
17	88,36	± 0,35	81,28	± 0,35
18	93,44	± 0,35	86,36	± 0,35
19	98,52	± 0,35	91,44	± 0,35
20	103,60	± 0,35	96,52	± 0,35
21	108,68	± 0,35	101,60	± 0,35
22	113,76	± 0,35	106,68	± 0,35
23	118,84	± 0,35	111,76	± 0,35
24	123,92	± 0,35	116,84	± 0,35

Screwless Terminal Block

Part No.: **A11M008**

Customer:

DRW:	Jason	CHKD	Wilson	MATL:	Wilson	TOLERANCE	Mason	DATE	03.02.2014
APPD:	Schumi			FINISH	Jamy		Sheet No.		2 from 4

EDCON-COMPONENTS

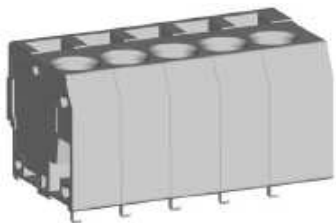

Ordering Informations

Serie	No. of Pos.	Body Color	Approval	Approval Code	ROHS	Packing	EDCON Cust. No.	Customer Version		
A11M008	02	GY	N	N	R	B				

Pitch:
5,08

02= Number of Pos. Standard 2~24 Pos.	GY= Gray (Standard)	N= No Approval	N= NON Approval	R= ROHS Conform	B= Standard Package	xxxxxx= Customer Number	xxx= Customer Version ??(Printing)
	GN= Green	1= Approval for Material	A= UL /UR Approval Please consult EDCON for available	N= NON ROHS Conform	I= Individual Package		
		2= Approval for Terminal Block	B= VDE Approval Please consult EDCON for available				
	OR= Orange		C= TÜV Approval Please consult EDCON for available				
	BK= Black						

Screwless Terminal Block

Part No.: **A11M008**

DRW:	Jason	CHKD	Wilson	MATL:	Wilson	TOLERANCE	Mason	DATE	03.02.2014
APPD:	Schumi			FINISH	Jamy		Sheet No.		3 from 4

Customer:

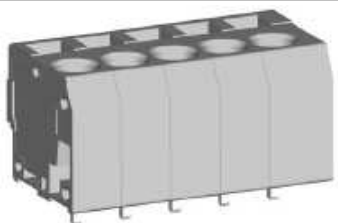

Soldering Profile Curve

Classification Reflow Profile (JEDEC J-STD-020C)

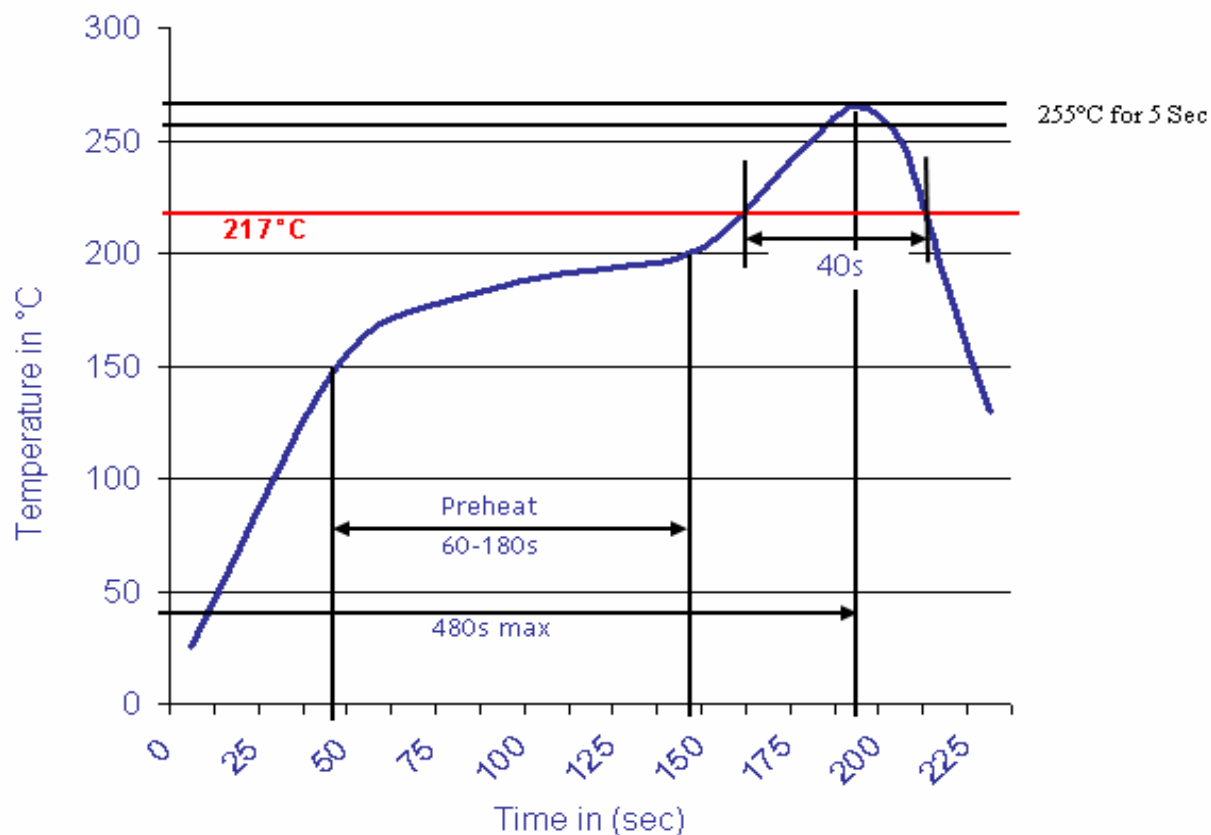

Screwless Terminal Block

Part No.: **A11M008**

Customer:

DRW:	Jason	CHKD	Wilson	MATL:	Wilson	TOLERANCE	Mason	DATE	03.02.2014
APPD:	Schumi			FINISH	Jamy		Sheet No.	4 from 4	

