

Data Sheet

Screwless Terminal Block

Pitch: 3,81 mm

Serie: A11H011

Customer Information for special Item

EDCON Customer : 0

Customer Version No. : 0

EDCON-COMPONENTS

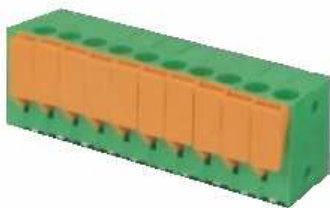

Technical Description

Drawing (Dimension in mm)

Electrical

Standard	cULus
Rated voltage	300V
Rated current	6A
Withstanding voltage	1.6KV
Solid wire	26-16 AWG
Stranded wire	26-16 AWG

Mechanical

Wire strip length	6 ~ 7mm
Operating temperature	-40°C ~ +115°C
Soldering temperature	250°C ±10°C/5 sec

Dimensions

Pitch	3.81mm
Poles	2P - 24P

Material

Housing	Thermoplastic (UL94V-0)
Pin header	Brass, Tin plated
Wire guard	Stainless steel

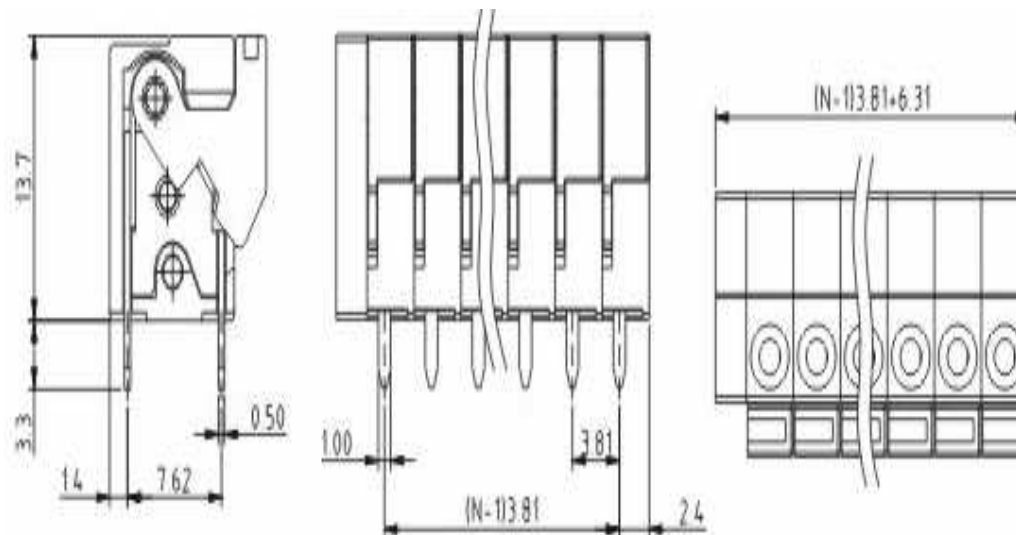

Screwless Terminal Block

Part No.: **A11H011**

Customer:

DRW:	Jason	CHKD	Wilson	MATL:	Wilson	TOLERANCE	Mason	DATE	30.01.2014
APPD:	Schumi			FINISH	Jamy		Sheet No.	1 from 4	

EDCON-COMPONENTS

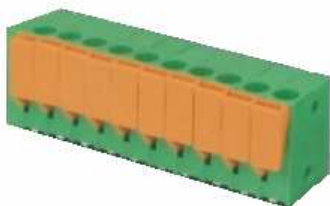

PCB Layout (Dimension in mm)

Dimensions (mm)

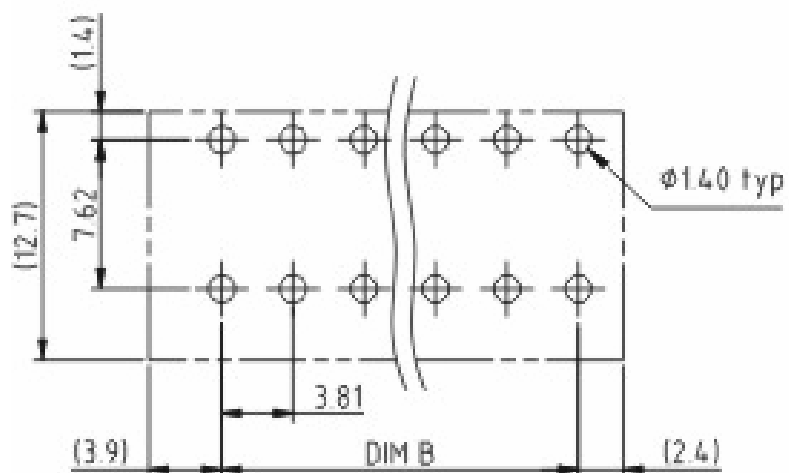

No. of Pos.	A	Tol. P	B	Tol. P
02	13,93	± 0,35	3,81	± 0,35
03	17,74	± 0,35	7,62	± 0,35
04	21,55	± 0,35	11,43	± 0,35
05	25,36	± 0,35	15,24	± 0,35
06	29,17	± 0,35	19,05	± 0,35
07	32,98	± 0,35	22,86	± 0,35
08	36,79	± 0,35	26,67	± 0,35
09	40,60	± 0,35	30,48	± 0,35
10	44,41	± 0,35	34,29	± 0,35
11	48,22	± 0,35	38,10	± 0,35
12	52,03	± 0,35	41,91	± 0,35
13	55,84	± 0,36	45,72	± 0,36
14	59,65	± 0,37	49,53	± 0,37
15	63,46	± 0,38	53,34	± 0,38
16	67,27	± 0,39	57,15	± 0,39
17	71,08	± 0,40	60,96	± 0,40
18	74,89	± 0,41	64,77	± 0,41
19	78,70	± 0,42	68,58	± 0,42
20	82,51	± 0,43	72,39	± 0,43
21	86,32	± 0,44	76,20	± 0,44
22	90,13	± 0,45	80,01	± 0,45
23	93,94	± 0,46	83,82	± 0,46
24	97,75	± 0,47	87,63	± 0,47

Screwless Terminal Block

Part No.: **A11H011**

DRW:	Jason	CHKD	Wilson	MATL:	Wilson	TOLERANCE	Mason	DATE	30.01.2014
APPD:	Schumi			FINISH	Jamy		Sheet No.		2 from 4

Customer:

EDCON-COMPONENTS

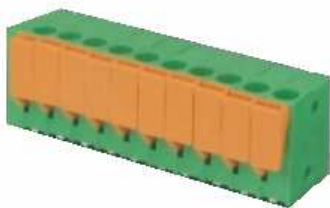

Ordering Informations

Serie	No. of Pos.	Body Color	Approval	Approval Code	ROHS	Packing	EDCON Cust. No.	Customer Version		
A11H011	02	GN	N	N	R	B				

Pitch:
3,81

02= Number of Pos. Standard 2 ~ 24Pos.	GY= Gray (Standard)	N= No Approval	N= NON Approval	R= ROHS Conform	B= Standard Package	xxxxxx= Customer Number	xxx= Customer Version ??(Printing)
	GN= Green	1= Approval for Material	A= UL /UR Approval Please consult EDCON for available	N= NON ROHS Conform	I= Individual Package		
	OR= Orange	2= Approval for Terminal Block	B= VDE Approval Please consult EDCON for available				
	BK= Black		C= TÜV Approval Please consult EDCON for available				

Screwless Terminal Block

Part No.: **A11H011**

DRW:	Jason	CHKD	Wilson	MATL:	Wilson	TOLERANCE	Mason	DATE	30.01.2014
APPD:	Schumi			FINISH	Jamy		Sheet No.		3 from 4

Customer:

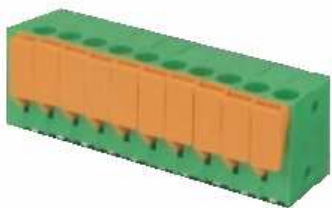

Soldering Profile Curve

Classification Reflow Profile (JEDEC J-STD-020C)

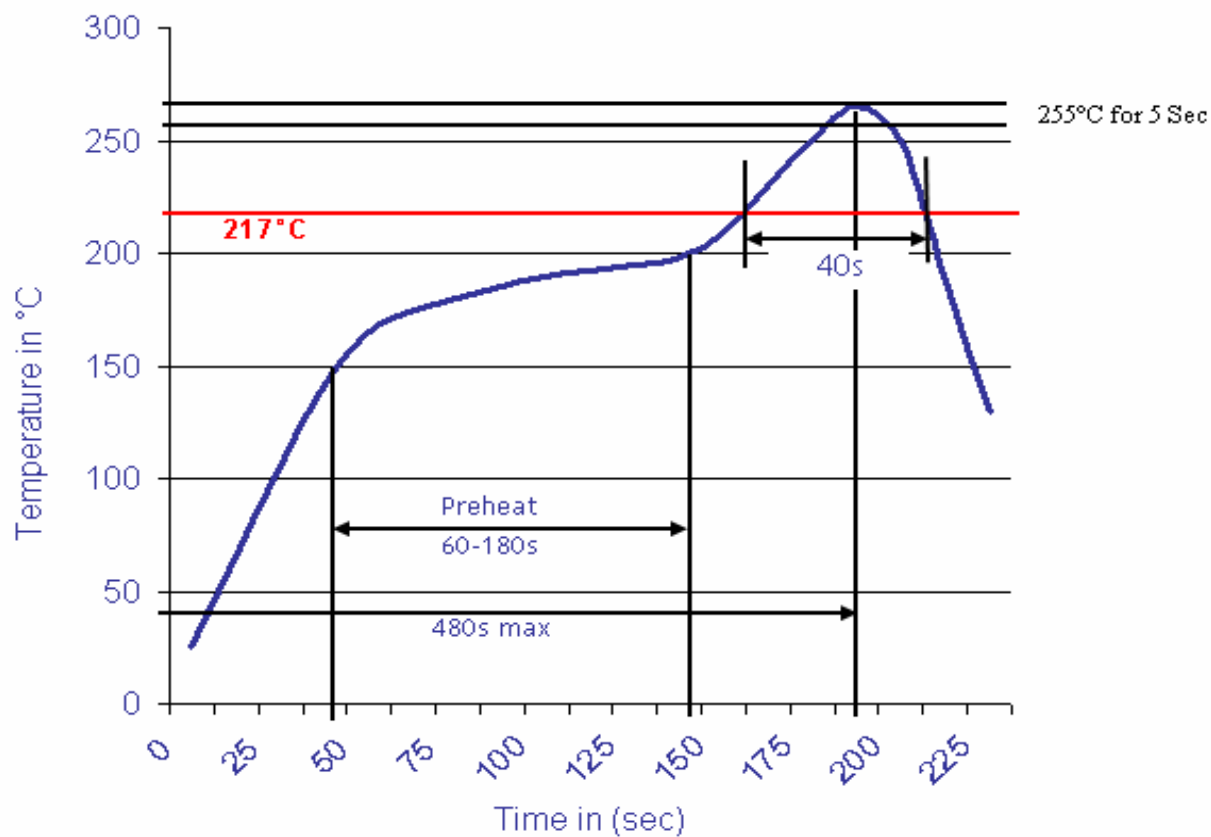

Screwless Terminal Block

Part No.: **A11H011**

Customer:

DRW:	Jason	CHKD	Wilson	MATL:	Wilson	TOLERANCE	Mason	DATE	30.01.2014
APPD:	Schumi			FINISH	Jamy		Sheet No.	4 from 4	

