

Data Sheet

Screwless Terminal Block

Pitch: 3,81 mm

Serie: A11H004

Customer Information for special Item

EDCON Customer : 0

Customer Version No. : 0

EDCON-COMPONENTS



Technical Discription

Drawing (Dimension in mm)

Electrical

Standard
 Rated voltage
 Rated current
 Wire range
 Withstanding voltage

cULus	IEC
300V	250V
5A	10A
20-18 AWG	1.5mm ²
AC2000V/1min	

Mechanical

Wire strip length
 Operating temperature

9 ~ 10mm
 -40°C ~ +105°C

Dimensions

Pitch
 Poles

3.81mm
 1P - xxP

Material

Housing
 Pin header
 Wire guard

PA66 (UL94V-0)
 Phosphor Bronze, Tin plated
 Stainless steel

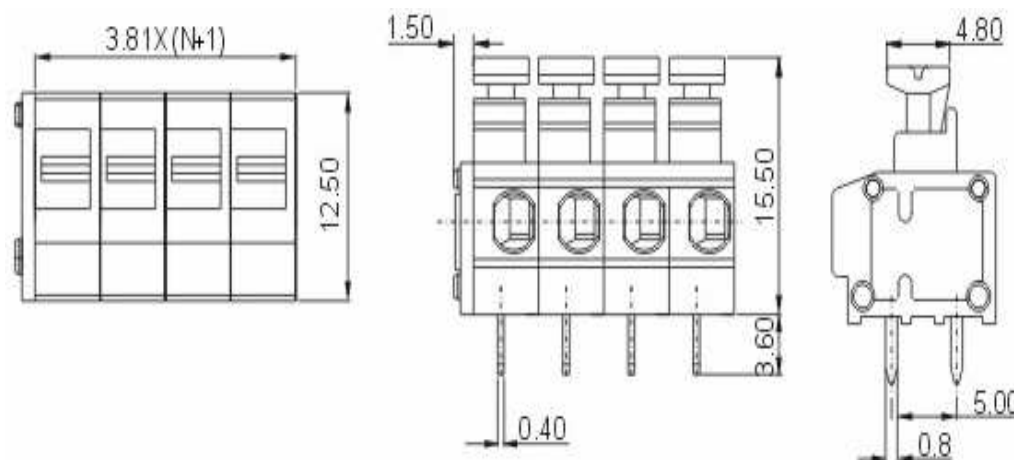

Screwless Terminal Block

Part No.: **A11H004**

Customer:

DRW:	Jason	CHKD	Wilson	MATL:	Wilson	TOLERANCE	Mason	DATE	30.01.2014
APPD:	Schumi			FINISH	Jamy		Sheet No.	1 from 4	

EDCON-COMPONENTS



PCB Layout (Dimension in mm)

Dimensions (mm)

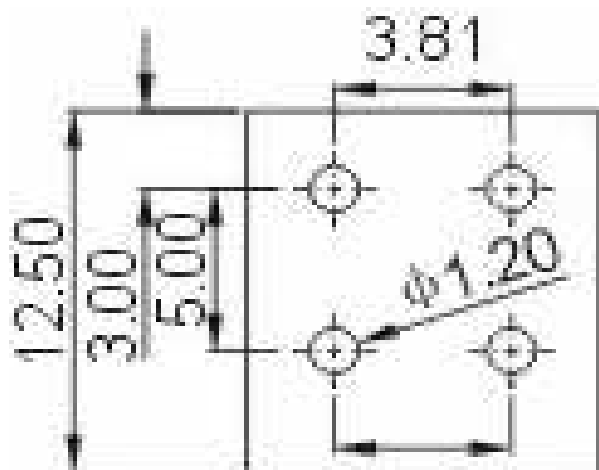

No. of Pos.	A	Tol. P	B	Tol. P
02	8,62	± 0,35	3,81	± 0,35
03	12,43	± 0,35	7,62	± 0,35
04	16,24	± 0,35	11,43	± 0,35
05	20,05	± 0,35	15,24	± 0,35
06	23,86	± 0,35	19,05	± 0,35
07	27,67	± 0,35	22,86	± 0,35
08	31,48	± 0,35	26,67	± 0,35
09	35,29	± 0,35	30,48	± 0,35
10	39,10	± 0,35	34,29	± 0,35
11	42,91	± 0,35	38,10	± 0,35
12	46,72	± 0,35	41,91	± 0,35
13	50,53	± 0,36	45,72	± 0,36
14	54,34	± 0,37	49,53	± 0,37
15	58,15	± 0,38	53,34	± 0,38
16	61,96	± 0,39	57,15	± 0,39
17	65,77	± 0,40	60,96	± 0,40
18	69,58	± 0,41	64,77	± 0,41
19	73,39	± 0,42	68,58	± 0,42
20	77,20	± 0,43	72,39	± 0,43
21	81,01	± 0,44	76,20	± 0,44
22	84,82	± 0,45	80,01	± 0,45
23	88,63	± 0,46	83,82	± 0,46
24	92,44	± 0,47	87,63	± 0,47

Screwless Terminal Block

Part No.: **A11H004**

DRW:	Jason	CHKD	Wilson	MATL:	Wilson	TOLERANCE	Mason	DATE	30.01.2014	Customer:
APPD:	Schumi			FINISH	Jamy		Sheet No.	2 from 4		

EDCON-COMPONENTS



Ordering Informations

Serie	No. of Pos.	Body Color	Approval	Approval Code	ROHS	Packing	EDCON Cust. No.	Customer Version		
-------	-------------	------------	----------	---------------	------	---------	-----------------	------------------	--	--

A11H004	02	GY	N	N	R	B				
----------------	-----------	-----------	----------	----------	----------	----------	--	--	--	--

Pitch	02= Number of Pos.	GY= Gray (Standard)	N= No Approval	N= NON Approval	R= ROHS Conform	B= Standard Package	xxxxxx= Customer Number	xxx= Customer Version ??(Printing)
-------	--------------------	---------------------	----------------	-----------------	-----------------	---------------------	-------------------------	------------------------------------

3,81	Standard 2 ~ 24Pos.	GN= Green	1= Approval for Material	A= UL /UR Approval Please consult EDCON for available	N= NON ROHS Conform	I= Individual Package		
		OR= Orange	2= Approval for Terminal Block	B= VDE Approval Please consult EDCON for available				
		BK= Black		C= TÜV Approval Please consult EDCON for available				

Screwless Terminal Block	
Part No.:	A11H004
Customer:	

DRW:	Jason	CHKD	Wilson	MATL:	Wilson	TOLERANCE	Mason	DATE	30.01.2014
APPD:	Schumi			FINISH	Jamy		Sheet No.		3 from 4



Soldering Profile Curve

Classification Reflow Profile (JEDEC J-STD-020C)

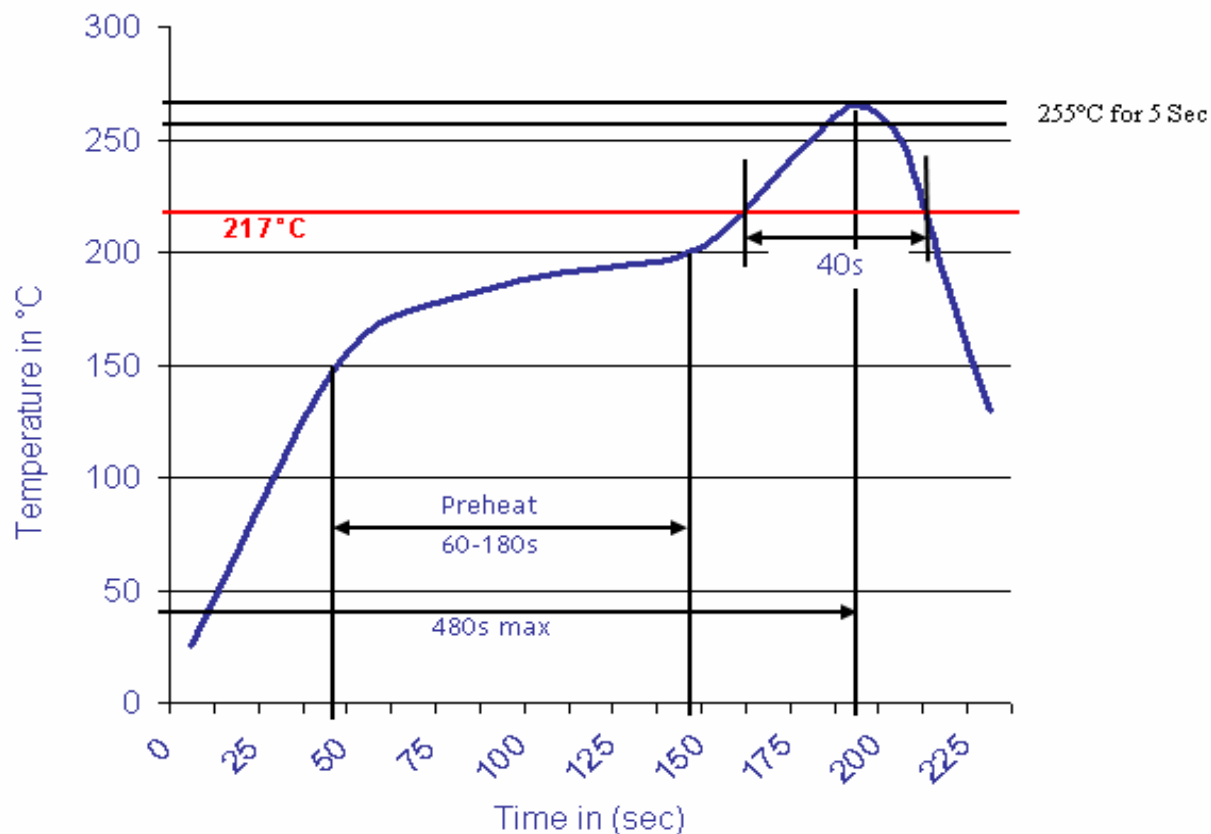

Screwless Terminal Block

Part No.: **A11H004**

Customer:

DRW:	Jason	CHKD	Wilson	MATL:	Wilson	TOLERANCE	Mason	DATE	30.01.2014
APPD:	Schumi			FINISH	Jamy		Sheet No.	4 from 4	

