

Data Sheet

Screwless Terminal Block

Pitch: 3,50 mm

Serie: A11G007

Customer Information for special Item

EDCON Customer : 0

Customer Version No. : 0

EDCON-COMPONENTS



Technical Discription

Drawing (Dimension in mm)

Electrical

Rated voltage	300V
Rated current	6A
Contact resistance	20mΩ
Insulation resistance	5000MΩ / 1000V
Wire range	26-16AWG / 1.5mm ²
Withstanding voltage	AC1500V/min

Mechanical

Operating temperature	-40°C ~ +105°C
Soldering temperature	+250°C/sec

Dimensions

Pitch	3.50mm
Poles	1P - xxP

Material

Housing	PA66 (UL94V-0)
Pin header	Brass, Tin-plated
Wire guard	Stainless steel

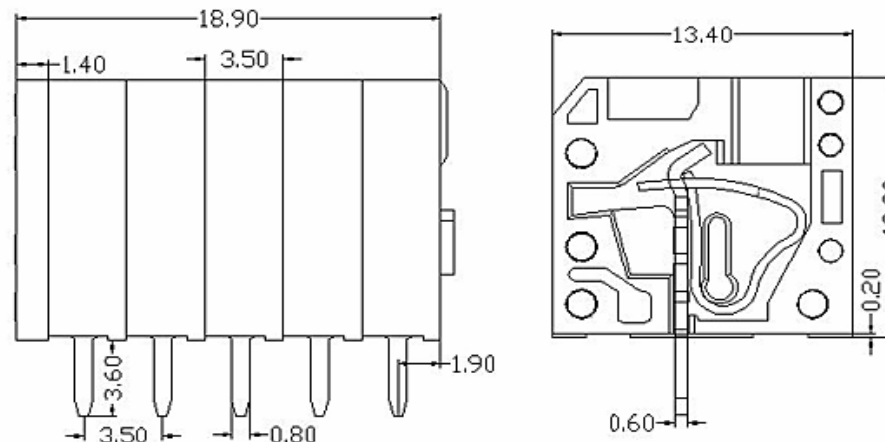

Screwless Terminal Block

Part No.: **A11G007**

Customer:

DRW:	Jason	CHKD	Wilson	MATL:	Wilson	TOLERANCE	Mason	DATE	28.01.2014
APPD:	Schumi			FINISH	Jamy		Sheet No.	1 from 4	

EDCON-COMPONENTS



PCB Layout (Dimension in mm)

Dimensions (mm)

No. of Pos.	A	Tol. P	B	Tol. P	
02	8,00	± 0,35	3,50	± 0,35	
03	11,50	± 0,35	7,00	± 0,35	
04	15,00	± 0,35	10,50	± 0,35	
05	18,50	± 0,35	14,00	± 0,35	
06	22,00	± 0,35	17,50	± 0,35	
07	25,50	± 0,35	21,00	± 0,35	
08	29,00	± 0,35	24,50	± 0,35	
09	32,50	± 0,35	28,00	± 0,35	
10	36,00	± 0,35	31,50	± 0,35	
11	39,50	± 0,35	35,00	± 0,35	
12	43,00	± 0,35	38,50	± 0,35	

Screwless Terminal Block

Part No.: **A11G007**

DRW:	Jason	CHKD	Wilson	MATL:	Wilson	TOLERANCE	Mason	DATE	28.01.2014	Customer:
APPD:	Schumi			FINISH	Jamy		Sheet No.	2 from 4		

EDCON-COMPONENTS



Ordering Informations

Serie	No. of Pos.	Body Color	Approval	Approval Code	ROHS	Packing	EDCON Cust. No.	Customer Version		
A11G007	02	GN	N	N	R	B				

Pitch 3,50	02 = Number of Pos.	GY = Gray (Standard)	N = No Approval	N = NON Approval	R = ROHS Conform	B = Standard Package	xxxxxx = Customer Number	xxx = Customer Version ??(Printing)
	Standard 2 ~ 24Pos.	GN = Green	1 = Approval for Material	A = UL /UR Approval Please consult EDCON for available	N = NON ROHS Conform	I = Individual Package		
		OR = Orange	2 = Approval for Terminal Block	B = VDE Approval Please consult EDCON for available				
		BK = Black		C = TÜV Approval Please consult EDCON for available				

Screwless Terminal Block	
Part No.:	A11G007
Customer:	

DRW:	Jason	CHKD	Wilson	MATL:	Wilson	TOLERANCE	Mason	DATE	28.01.2014
APPD:	Schumi			FINISH	Jamy		Sheet No.		3 from 4



Soldering Profile Curve

Classification Reflow Profile (JEDEC J-STD-020C)



Screwless Terminal Block

Part No.: **A11G007**

Customer:

DRW:	Jason	CHKD	Wilson	MATL:	Wilson	TOLERANCE	Mason	DATE	28.01.2014
APPD:	Schumi			FINISH	Jamy		Sheet No.	4 from 4	

