

# Data Sheet

## Screwless Terminal Block

**Pitch: 3,50 mm**

**Serie: A11G006**

### Customer Information for special Item

**EDCON Customer : 0**

**Customer Version No. : 0**

# EDCON-COMPONENTS



## Technical Discription

## Drawing (Dimension in mm)

### Electrical

Standard	cULus
Rated voltage	300V
Rated current	2A
Push-Wire connection	AWG 20-26 "sol"
Wire strip length	7.5 ~ 8.5mm
IDC connection	AWG 22"sol"
Withstanding voltage	1.6KV

### Mechanical

Operating temperature	-40°C ~ +115°C
Soldering temperature	250°C ±10°C/5sec

### Dimensions

Pitch	3.50mm
Poles	2P - 12P

### Material

Housing	Thermoplastic (UL94V-0)
Pin header	Phosphor Bronze, Tin plated

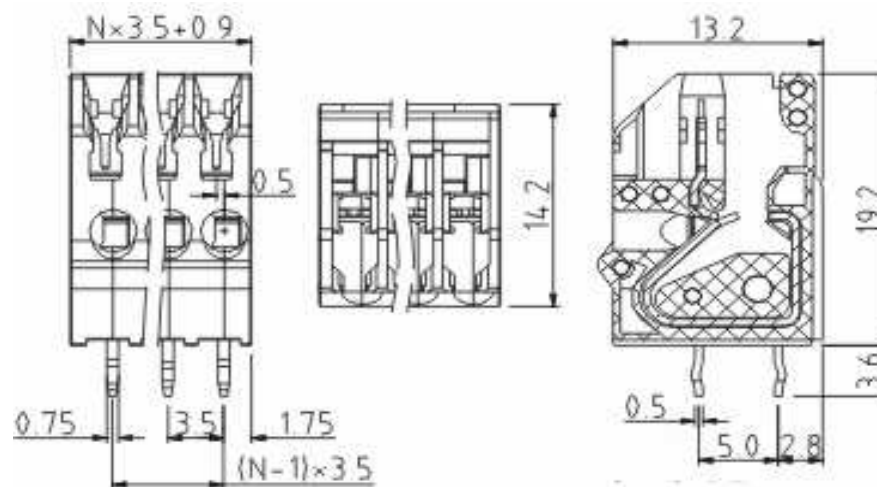

### Screwless Terminal Block

Part No.: **A11G006**

Customer:

DRW:	Jason	CHKD	Wilson	MATL:	Wilson	TOLERANCE	Mason	DATE	28.01.2014
APPD:	Schumi			FINISH	Jamy		Sheet No.	1 from 4	



# EDCON-COMPONENTS



## Ordering Informations

Serie	No. of Pos.	Body Color	Approval	Approval Code	ROHS	Packing	EDCON Cust. No.	Customer Version		
<b>A11G006</b>	<b>02</b>	<b>GN</b>	<b>N</b>	<b>N</b>	<b>R</b>	<b>B</b>				

Pitch 3,50	<b>02</b> = Number of Pos. Standard 2 ~ 24Pos.	<b>GY</b> = Gray (Standard)	<b>N</b> = No Approval	<b>N</b> = NON Approval	<b>R</b> = ROHS Conform	<b>B</b> = Standard Package	<b>xxxxxx</b> = Customer Number	<b>xxx</b> = Customer Version ??(Printing)
		<b>GN</b> = Green	<b>1</b> = Approval for Material	<b>A</b> = UL /UR Approval Please consult EDCON for available	<b>N</b> = NON ROHS Conform	<b>I</b> = Individual Package		
		<b>OR</b> = Orange	<b>2</b> = Approval for Terminal Block	<b>B</b> = VDE Approval Please consult EDCON for available				
		<b>BK</b> = Black		<b>C</b> = TÜV Approval Please consult EDCON for available				

<b>Screwless Terminal Block</b>	
Part No.:	<b>A11G006</b>
Customer:	

DRW:	Jason	CHKD	Wilson	MATL:	Wilson	TOLERANCE	Mason	DATE	28.01.2014
APPD:	Schumi			FINISH	Jamy		Sheet No.		3 from 4



Soldering Profile Curve

Classification Reflow Profile (JEDEC J-STD-020C)



**Screwless Terminal Block**

Part No.: **A11G006**

Customer:

DRW:	Jason	CHKD	Wilson	MATL:	Wilson	TOLERANCE	Mason	DATE	28.01.2014
APPD:	Schumi			FINISH	Jamy		Sheet No.	4 from 4	



