

Data Sheet

Screwless Terminal Block

Pitch: 3,50 mm

Serie: A11G003

Customer Information for special Item

EDCON Customer : 0

Customer Version No. : 0

EDCON-COMPONENTS



First pin back



Technical Discription

Drawing (Dimension in mm)

Electrical:

Standard UL, VDE
 Rated voltage 250V
 Rated current 2A
 Wire range 14-22 AWG

Mechanical

Operating temperature -40°C ~ +105°C

Dimensions

Pitch 3.5mm
 Poles 2P - 24P

Material

Housing Nylon PA66 (UL94V-0)
 Pin header Brass, Tin plated
 Wire guard Stainless steel

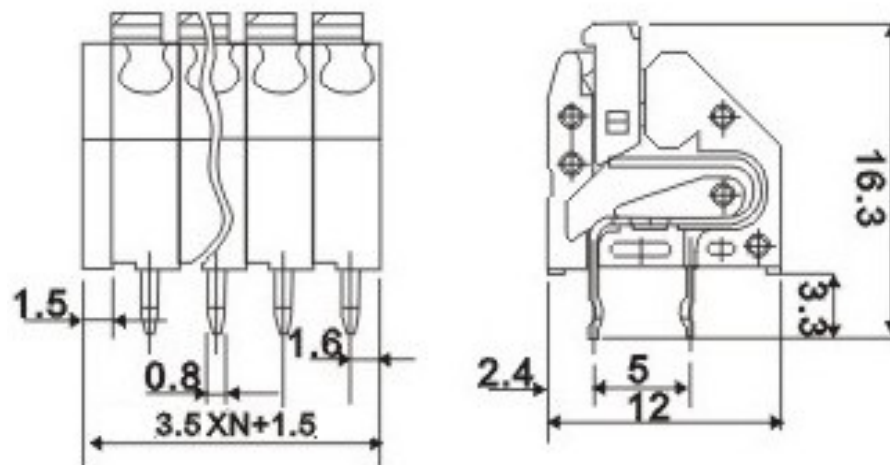

Screwless Terminal Block

Part No.: **A11G003**

Customer:

DRW:	Jason	CHKD	Wilson	MATL:	Wilson	TOLERANCE	Mason	DATE	10.11.2014
APPD:	Schumi			FINISH	Jamy		Sheet No.		1 from 4

EDCON-COMPONENTS



First pin back



PCB Layout (Dimension in mm)

Dimensions (mm)

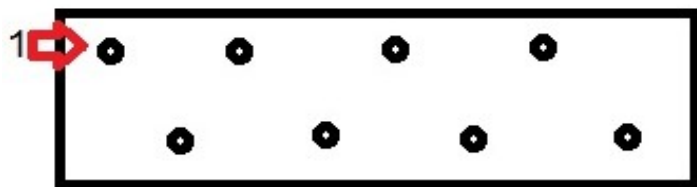
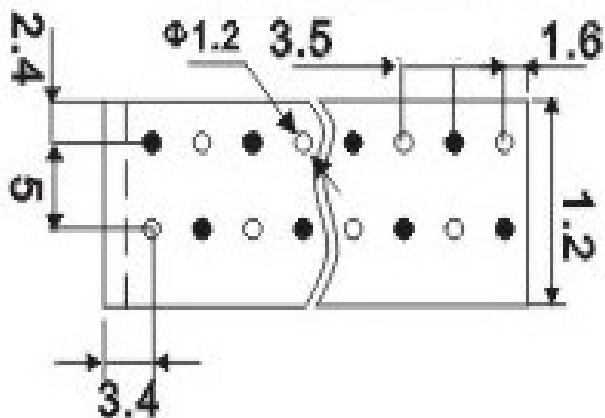

Frontside = Cable entry side

No. of Pos.	A	Tol. P	B	Tol. P
02	8,50	± 0,35	3,50	± 0,35
03	12,00	± 0,35	7,00	± 0,35
04	15,50	± 0,35	10,50	± 0,35
05	19,00	± 0,35	14,00	± 0,35
06	22,50	± 0,35	17,50	± 0,35
07	26,00	± 0,35	21,00	± 0,35
08	29,50	± 0,35	24,50	± 0,35
09	33,00	± 0,35	28,00	± 0,35
10	36,50	± 0,35	31,50	± 0,35
11	40,00	± 0,35	35,00	± 0,35
12	43,50	± 0,35	38,50	± 0,35
13	47,00	± 0,35	42,00	± 0,35
14	50,50	± 0,35	45,50	± 0,35
15	54,00	± 0,35	49,00	± 0,35
16	57,50	± 0,35	52,50	± 0,35
17	61,00	± 0,35	56,00	± 0,35
18	64,50	± 0,35	59,50	± 0,35
19	68,00	± 0,35	63,00	± 0,35
20	71,50	± 0,35	66,50	± 0,35
21	75,00	± 0,35	70,00	± 0,35
22	78,50	± 0,35	73,50	± 0,35
23	82,00	± 0,35	77,00	± 0,35
24	85,50	± 0,35	80,50	± 0,35

Screwless Terminal Block

Part No.: **A11G003**

DRW:	Jason	CHKD	Wilson	MATL:	Wilson	TOLERANCE	Mason	DATE	27.03.2022
APPD:	Schumi			FINISH	Jamy		Sheet No.		2 from 4

Customer:

EDCON-COMPONENTS



First pin back



Ordering Informations

Serie	No. of Pos.	Body Color	Approval	Approval Code	ROHS	Packing	EDCON Cust. No.	Customer Version		
A11G003	02	GY	N	N	R	B				

Pitch
3,50

02= Number of Pos. Standard 2 ~ 24Pos.	GY= Gray (Standard)	0= No Approval	0= NON Approval	R= ROHS Conform	B= Standard Package	xxxxxx= Customer Number	xxx= Customer Version ??(Printing)
	GN= Green	N= Approval for Material	N= UL /UR Approval	N= NON ROHS Conform	I= Individual Package		
	OR= Orange	2= Approval for Terminal Block	B= VDE Approval Please consult EDCON for available				
	BK= Black		C= TÜV Approval Please consult EDCON for available				

Screwless Terminal Block	
Part No.:	A11G003
Customer:	

DRW:	Jason	CHKD	Wilson	MATL:	Wilson	TOLERANCE	Mason	DATE	10.11.2014
APPD:	Schumi			FINISH	Jamy		Sheet No.		3 from 4



First pin back



Soldering Profile Curve

Classification Reflow Profile (JEDEC J-STD-020C)

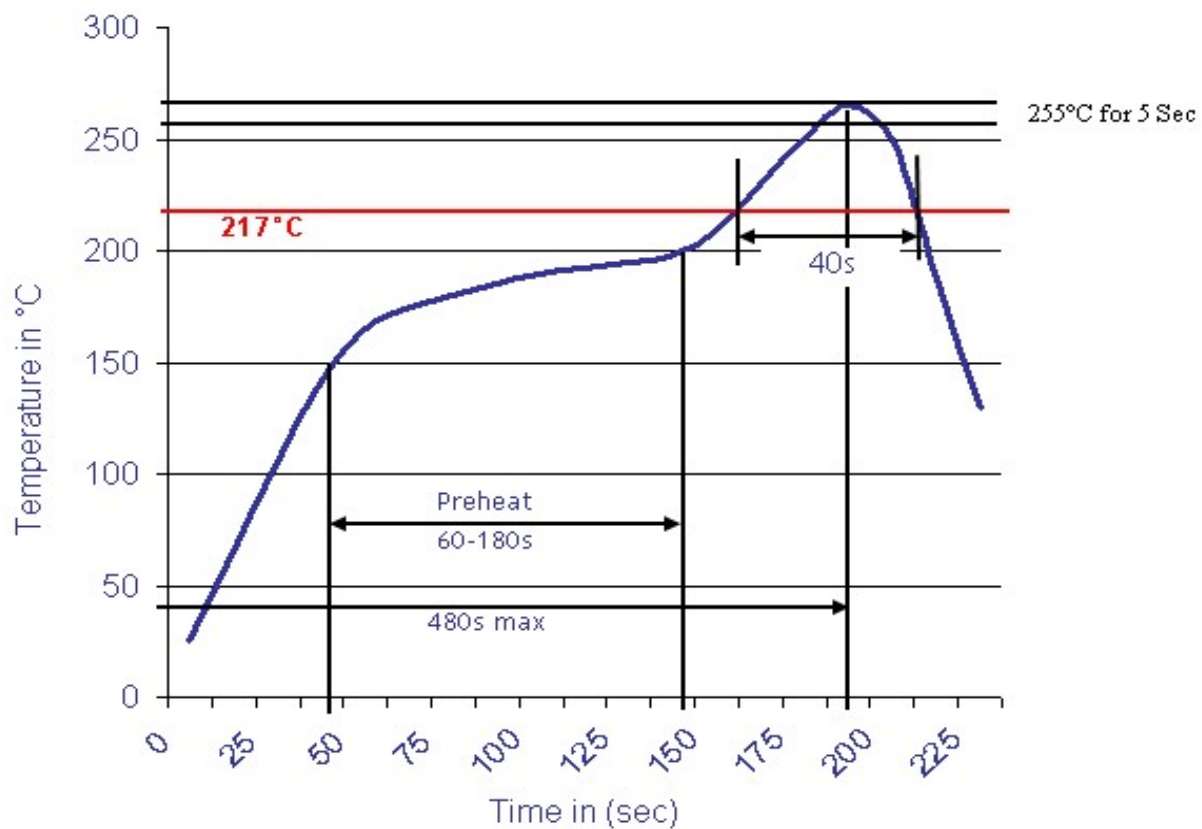

Screwless Terminal Block	
Part No.:	A11G003
Customer:	

DRW:	Jason	CHKD	Wilson	MATL:	Wilson	TOLERANCE	Mason	DATE	10.11.2014
APPD:	Schumi			FINISH	Jamy		Sheet No.	4 from 4	

