

Data Sheet

Screwless Terminal Block

Pitch: 2,54 mm

Serie: A11F011

Customer Information for special Item

EDCON Customer : 0

Customer Version No. : 0

EDCON-COMPONENTS

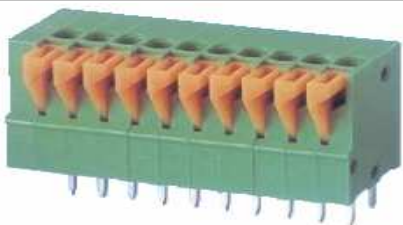

Technical Discription

Drawing (Dimension in mm)

Electrical

Standard	UL, VDE
Rated voltage	150V
Rated current	2A
Wire range	20-26 AWG

Mechanical

Operating temperature	-40°C ~ +105°C
-----------------------	----------------

Dimensions

Pitch	2.54mm
Poles	1P - xxP

Material

Housing	Nylon PA66 (UL94V-0)
Pin header	Brass, Tin plated
Wire guard	Stainless steel

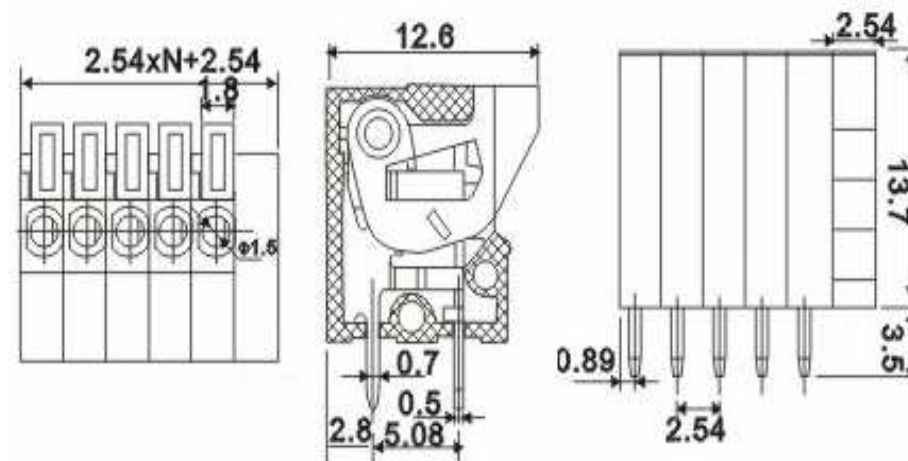

Screwless Terminal Block

Part No.: **A11F011**

Customer:

DRW:	Jason	CHKD	Wilson	MATL:	Wilson	TOLERANCE	Mason	DATE	28.01.2014
APPD:	Schumi			FINISH	Jamy		Sheet No.	1 from 4	

EDCON-COMPONENTS

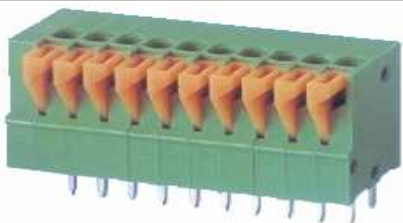

PCB Layout (Dimension in mm)

Dimensions (mm)

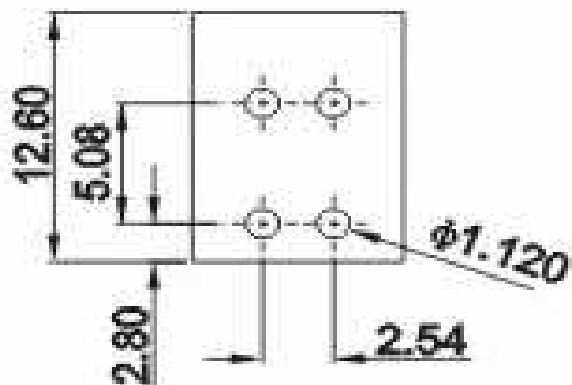

No. of Pos.	A	Tol. P	B	Tol. P
02	7,53	± 0,30	2,54	± 0,35
03	10,07	± 0,30	5,08	± 0,35
04	12,61	± 0,30	7,62	± 0,35
05	15,15	± 0,30	10,16	± 0,35
06	17,69	± 0,30	12,70	± 0,35
07	20,23	± 0,30	15,24	± 0,35
08	22,77	± 0,30	17,78	± 0,35
09	25,31	± 0,30	20,32	± 0,35
10	27,85	± 0,30	22,86	± 0,35
11	30,39	± 0,30	25,40	± 0,35
12	32,93	± 0,30	27,94	± 0,35
13	35,47	± 0,31	30,48	± 0,36
14	38,01	± 0,32	33,02	± 0,37
15	40,55	± 0,33	35,56	± 0,38
16	43,09	± 0,34	38,10	± 0,39
17	45,63	± 0,35	40,64	± 0,40
18	48,17	± 0,36	43,18	± 0,41
19	50,71	± 0,37	45,72	± 0,42
20	53,25	± 0,38	48,26	± 0,43
21	55,79	± 0,39	50,80	± 0,44
22	58,33	± 0,40	53,34	± 0,45
23	60,87	± 0,41	55,88	± 0,46
24	63,41	± 0,42	58,42	± 0,47

Screwless Terminal Block

Part No.: **A11F011**

DRW:	Jason	CHKD	Wilson	MATL:	Wilson	TOLERANCE	Mason	DATE	28.01.2014
APPD:	Schumi			FINISH	Jamy		Sheet No.		2 from 4

Customer:

EDCON-COMPONENTS

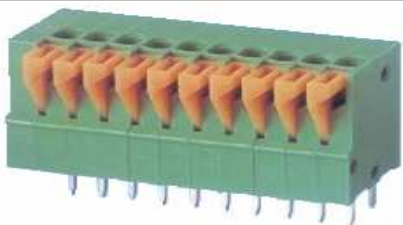

Ordering Informations

Serie	No. of Pos.	Body Color	Approval	Approval Code	ROHS	Packing	EDCON Cust. No.	Customer Version		
A11F011	02	GN	N	N	R	B				

Pitch 2,54	02= Number of Pos. Standard 2 ~ 24Pos.	GY= Gray (Standard) GN= Green OR= Orange BK= Black	N= No Approval 1= Approval for Material 2= Approval for Terminal Block	N= NON Approval A= UL /UR Approval Please consult EDCON for available B= VDE Approval Please consult EDCON for available C= TÜV Approval Please consult EDCON for available	R= ROHS Conform N= NON ROHS Conform	B= Standard Package I= Individual Package	xxxxxx= Customer Number	xxx= Customer Version ??(Printing)
---------------	---	--	--	--	---	---	-------------------------	------------------------------------

Screwless Terminal Block	
Part No.:	A11F011
Customer:	

DRW:	Jason	CHKD	Wilson	MATL:	Wilson	TOLERANCE	Mason	DATE	28.01.2014
APPD:	Schumi			FINISH	Jamy		Sheet No.		3 from 4

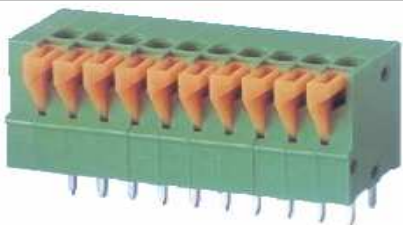

Soldering Profile Curve

Classification Reflow Profile (JEDEC J-STD-020C)



Screwless Terminal Block

Part No.: **A11F011**

Customer:

DRW:	Jason	CHKD	Wilson	MATL:	Wilson	TOLERANCE	Mason	DATE	28.01.2014
APPD:	Schumi			FINISH	Jamy		Sheet No.	4 from 4	

