

Data Sheet

Screwless Terminal Block

Pitch: 2,54 mm

Serie: A11F006

Customer Information for special Item

EDCON Customer : 0

Customer Version No. : 0

EDCON-COMPONENTS



Technical Discription

Drawing (Dimension in mm)

Electrical

Standard	cUL	VDE
Rated voltage	150V	130V
Rated current	4A	6A
Wire range	28-20 AWG	0.2-0.5mm ²

Mechanical

Operating temperature -40°C ~ +105°C

Dimensions

Pitch 2.54mm
Poles 2P - 24P

Material

Housing Polyamide66 (UL94V-0)
Pin header Brass, Tin plated
Wire guard Stainless strip steel

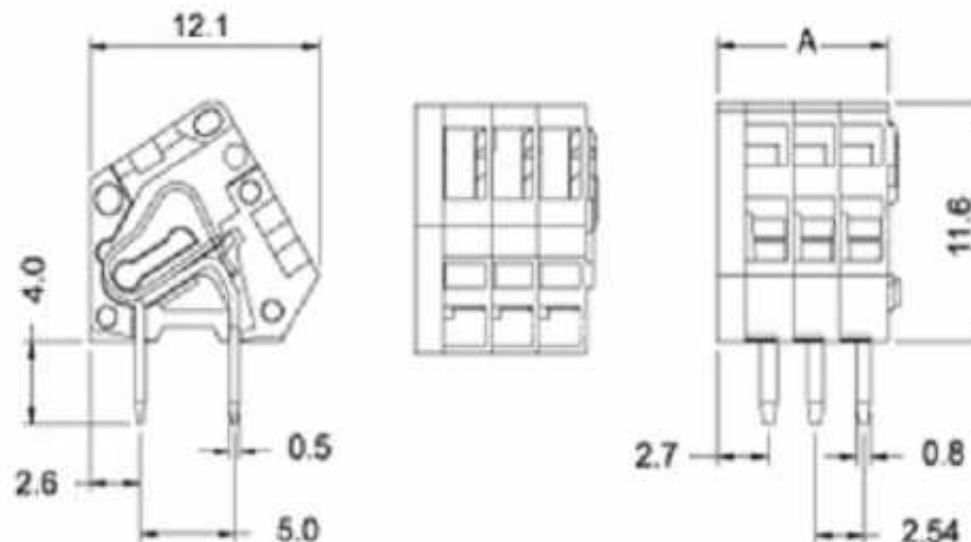

Screwless Terminal Block

Part No.: **A11F006**

Customer:

DRW:	Jason	CHKD	Wilson	MATL:	Wilson	TOLERANCE	Mason	DATE	28.01.2014
APPD:	Schumi			FINISH	Jamy		Sheet No.	1 from 4	

EDCON-COMPONENTS



PCB Layout (Dimension in mm)

Dimensions (mm)

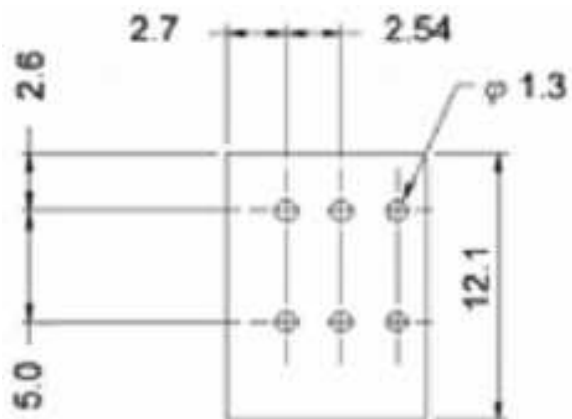

No. of Pos.	A	Tol. P	B	Tol. P
02	7,38	± 0,30	2,54	± 0,35
03	9,92	± 0,30	5,08	± 0,35
04	12,46	± 0,30	7,62	± 0,35
05	15,00	± 0,30	10,16	± 0,35
06	17,54	± 0,30	12,70	± 0,35
07	20,08	± 0,30	15,24	± 0,35
08	22,62	± 0,30	17,78	± 0,35
09	25,16	± 0,30	20,32	± 0,35
10	27,70	± 0,30	22,86	± 0,35
11	30,24	± 0,30	25,40	± 0,35
12	32,78	± 0,30	27,94	± 0,35
13	35,32	± 0,31	30,48	± 0,36
14	37,86	± 0,32	33,02	± 0,37
15	40,40	± 0,33	35,56	± 0,38
16	42,94	± 0,34	38,10	± 0,39
17	45,48	± 0,35	40,64	± 0,40
18	48,02	± 0,36	43,18	± 0,41
19	50,56	± 0,37	45,72	± 0,42
20	53,10	± 0,38	48,26	± 0,43
21	55,64	± 0,39	50,80	± 0,44
22	58,18	± 0,40	53,34	± 0,45
23	60,72	± 0,41	55,88	± 0,46
24	63,26	± 0,42	58,42	± 0,47

Screwless Terminal Block

Part No.: **A11F006**

DRW:	Jason	CHKD	Wilson	MATL:	Wilson	TOLERANCE	Mason	DATE	28.01.2014
APPD:	Schumi			FINISH	Jamy		Sheet No.	2 from 4	Customer:

EDCON-COMPONENTS



Ordering Informations

Serie	No. of Pos.	Body Color	Approval	Approval Code	ROHS	Packing	EDCON Cust. No.	Customer Version		
-------	-------------	------------	----------	---------------	------	---------	-----------------	------------------	--	--

A11F006	02	OR	N	N	R	B				
----------------	-----------	-----------	----------	----------	----------	----------	--	--	--	--

Pitch	02= Number of Pos.	GY= Gray (Standard)	N= No Approval	N= NON Approval	R= ROHS Conform	B= Standard Package	xxxxxx= Customer Number	xxx= Customer Version ??(Printing)
-------	--------------------	---------------------	----------------	-----------------	-----------------	---------------------	-------------------------	------------------------------------

2,54	Standard 2 ~ 24Pos.		1= Approval for Material	A= UL /UR Approval Please consult EDCON for available	N= NON ROHS Conform	I= Individual Package		
		GN= Green	2= Approval for Terminal Block					
				B= VDE Approval Please consult EDCON for available				
		OR= Orange						
		BK= Black		C= TÜV Approval Please consult EDCON for available				

Screwless Terminal Block	
Part No.:	A11F006
Customer:	

DRW:	Jason	CHKD	Wilson	MATL:	Wilson	TOLERANCE	Mason	DATE	28.01.2014
APPD:	Schumi			FINISH	Jamy			Sheet No.	3 from 4



Soldering Profile Curve

Classification Reflow Profile (JEDEC J-STD-020C)



Screwless Terminal Block

Part No.: **A11F006**

Customer:

DRW:	Jason	CHKD	Wilson	MATL:	Wilson	TOLERANCE	Mason	DATE	28.01.2014
APPD:	Schumi			FINISH	Jamy		Sheet No.	4 from 4	

