

Data Sheet

Screwless Terminal Block

Pitch: 2,54 mm

Serie: A11F002

Customer Information for special Item

EDCON Customer : 0

Customer Version No. : 0

EDCON-COMPONENTS

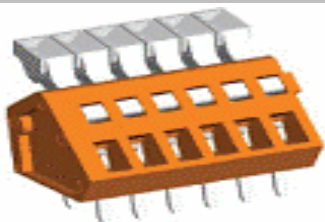

Technical Description

Drawing (Dimension in mm)

Electrical

Standard	UL
Rated voltage	150V
Rated current	4A
Solid wire	28-22 AWG
Stranded wire	28-22 AWG
Withstanding voltage	1.3 KV

Mechanical

Operating temperature	-40°C ~ +115°C
Soldering temperature	250°C ± 10°C/5sec
Strip length	6 ~ 7mm

Dimensions

Pitch	2.54mm
Poles	1P - xxP

Material

Housing	Thermoplastic (UL94V-0)
Pin header	Brass
Wire guard	Stainless steel

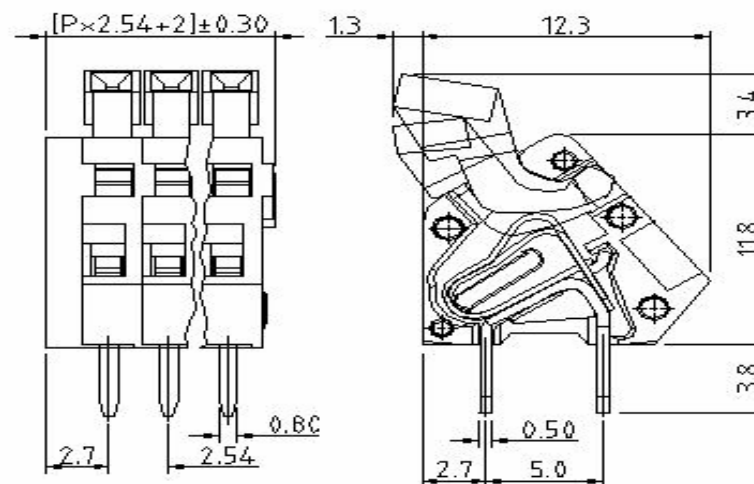

Screwless Terminal Block

Part No.: **A11F002**

Customer:

DRW:	Jason	CHKD	Wilson	MATL:	Wilson	TOLERANCE	Mason	DATE	28.01.2014
APPD:	Schumi			FINISH	Jamy		Sheet No.	1 from 4	

EDCON-COMPONENTS

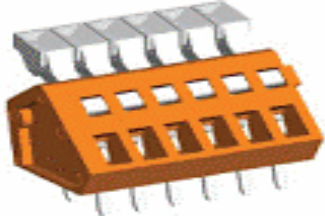

PCB Layout (Dimension in mm)

Dimensions (mm)

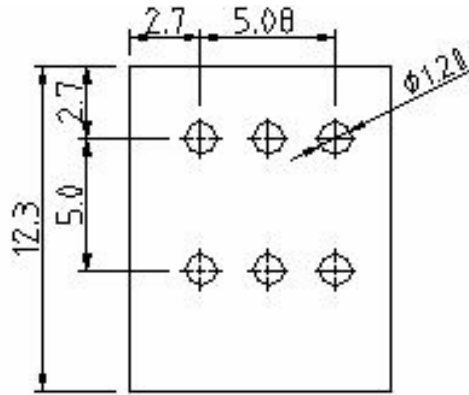

No. of Pos.	A	Tol. P	B	Tol. P	
02	7,08	± 0,30	2,54	± 0,35	
03	9,62	± 0,30	5,08	± 0,35	
04	12,16	± 0,30	7,62	± 0,35	
05	14,70	± 0,30	10,16	± 0,35	
06	17,24	± 0,30	12,70	± 0,35	
07	19,78	± 0,30	15,24	± 0,35	
08	22,32	± 0,30	17,78	± 0,35	
09	24,86	± 0,30	20,32	± 0,35	
10	27,40	± 0,30	22,86	± 0,35	
11	29,94	± 0,30	25,40	± 0,35	
12	32,48	± 0,30	27,94	± 0,35	

Screwless Terminal Block

Part No.: **A11F002**

DRW:	Jason	CHKD	Wilson	MATL:	Wilson	TOLERANCE	Mason	DATE	28.01.2014
APPD:	Schumi			FINISH	Jamy		Sheet No.		2 from 4

Customer:

EDCON-COMPONENTS

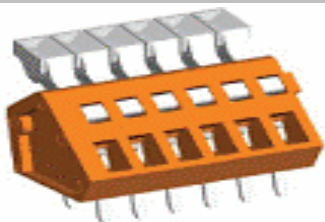

Ordering Informations

Serie	No. of Pos.	Body Color	Approval	Approval Code	ROHS	Packing	EDCON Cust. No.	Customer Version		
-------	-------------	------------	----------	---------------	------	---------	-----------------	------------------	--	--

A11F002	02	OR	N	N	R	B				
----------------	-----------	-----------	----------	----------	----------	----------	--	--	--	--

Pitch	02= Number of Pos.	GY= Gray (Standard)	N= No Approval	N= NON Approval	R= ROHS Conform	B= Standard Package	xxxxxx= Customer Number	xxx= Customer Version ??(Printing)
-------	--------------------	---------------------	----------------	-----------------	-----------------	---------------------	-------------------------	------------------------------------

2,54	Standard 2 ~ 24Pos.		1= Approval for Material	A= UL /UR Approval Please consult EDCON for available	N= NON ROHS Conform	I= Individual Package		
		GN= Green	2= Approval for Terminal Block					
				B= VDE Approval Please consult EDCON for available				
		OR= Orange						
		BK= Black		C= TÜV Approval Please consult EDCON for available				

Screwless Terminal Block	
Part No.:	A11F002
Customer:	

DRW:	Jason	CHKD	Wilson	MATL:	Wilson	TOLERANCE	Mason	DATE	28.01.2014
APPD:	Schumi			FINISH	Jamy			Sheet No.	3 from 4

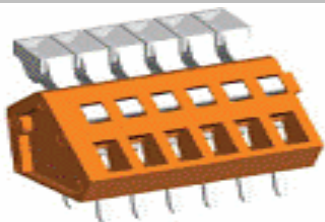

Soldering Profile Curve

Classification Reflow Profile (JEDEC J-STD-020C)

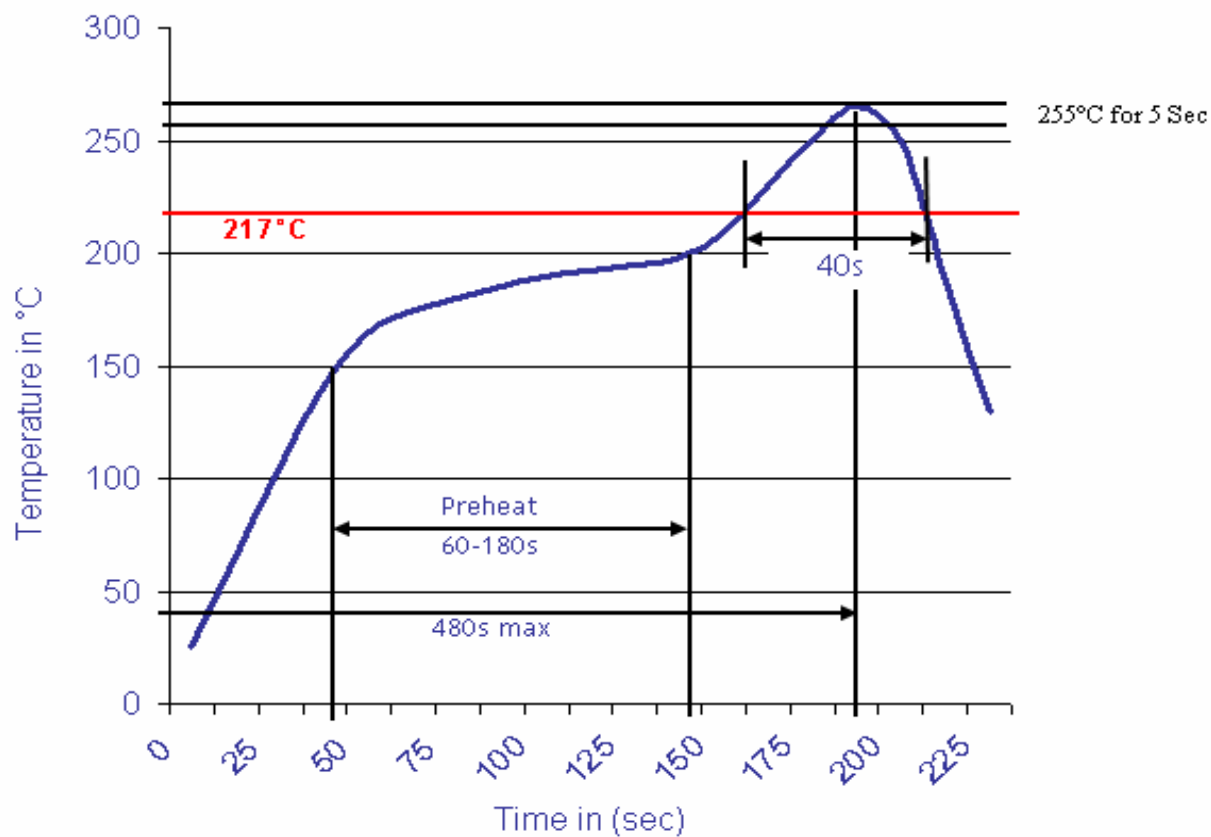

Screwless Terminal Block

Part No.: **A11F002**

Customer:

DRW:	Jason	CHKD	Wilson	MATL:	Wilson	TOLERANCE	Mason	DATE	28.01.2014
APPD:	Schumi			FINISH	Jamy		Sheet No.	4 from 4	

